



SERVICE MANUAL

D-NET DIESEL GENERATORS

7.6KW - 60Hz /5.7KW - 50Hz EDT

5.5KW - 60Hz /5.0KW - 50Hz EDC

Single Phase

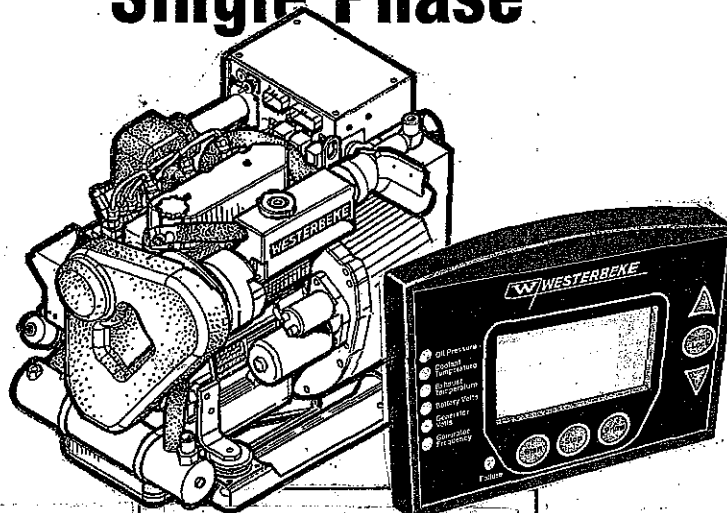

PUBLICATION NO. 054560

REVISION 1

MARCH 2010

WESTERBEKE



WESTERBEKE CORPORATION • MYLES STANDISH INDUSTRIAL PARK
150 JOHN HANCOCK ROAD • TAUNTON MA 02780-7319 • TEL. 1-508-823-7677
FAX 1-508-884-9688 • WEBSITE: WWW.WESTERBEKE.COM

⚠ WARNING

Exhaust gasses contain Carbon Monoxide, an odorless and colorless gas. Carbon Monoxide is poisonous and can cause unconsciousness and death. Symptoms of Carbon Monoxide exposure can include:

- Dizziness
- Nausea
- Headache
- Weakness and Sleepiness
- Throbbing in Temples
- Muscular Twitching
- Vomiting
- Inability to Think Coherently

IF YOU OR ANYONE ELSE EXPERIENCE ANY OF THESE SYMPTOMS, GET OUT INTO THE FRESH AIR IMMEDIATELY. If symptoms persist, seek medical attention. Shut down the unit and do not restart until it has been inspected and repaired.



A WARNING DECAL is provided by WESTERBEKE and should be fixed to a bulkhead near your engine or generator. WESTERBEKE also recommends installing CARBON MONOXIDE DETECTORS in the living/sleeping quarters of your vessel. They are inexpensive and easily obtainable at your local marine store.

**CALIFORNIA
PROPOSITION 65 WARNING**

Marine diesel and gasoline engine exhaust and some of its constituents are known to the State of California to cause cancer, birth defects, and other reproductive harm.

SAFETY INSTRUCTIONS

INTRODUCTION

Read this safety manual carefully. Most accidents are caused by failure to follow fundamental rules and precautions. Know when dangerous conditions exist and take the necessary precautions to protect yourself, your personnel, and your machinery.

The following safety instructions are in compliance with the American Boat and Yacht Council (ABYC) standards.

PREVENT ELECTRIC SHOCK

⚠ WARNING: Do not touch AC electrical connections while engine is running. Lethal voltage is present at these connections!

- Do not operate this machinery without electrical enclosures and covers in place.
- Shut off electrical power before accessing electrical equipment.
- Use insulated mats whenever working on electrical equipment.
- Make sure your clothing and skin are dry, not damp (particularly shoes) when handling electrical equipment.
- Remove wristwatch and all jewelry when working on electrical equipment.
- Electrical shock results from handling a charged capacitor. Discharge capacitor by shorting terminals together.

PREVENT BURNS — HOT ENGINE

⚠ WARNING: Do not touch hot engine parts or exhaust system components. A running engine gets very hot!

- Always check the engine coolant level at the coolant recovery tank.

⚠ WARNING: Steam can cause injury or death!

- In case of an engine overheat, allow the engine to cool before touching the engine or checking the coolant.

PREVENT BURNS — FIRE

⚠ WARNING: Fire can cause injury or death!

- Prevent flash fires. Do not smoke or permit flames or sparks to occur near the carburetor, fuel line, filter, fuel pump, or other potential sources of spilled fuel or fuel vapors. Use a suitable container to catch all fuel when removing the fuel line, carburetor, or fuel filters.

- Do not operate with the air cleaner/silencer removed. Backfire can cause severe injury or death.
- Do not smoke or permit flames or sparks to occur near the fuel system. Keep the compartment and the engine/generator clean and free of debris to minimize the chances of fire. Wipe up all spilled fuel and engine oil.
- Be aware — Diesel fuel will burn.

PREVENT BURNS — EXPLOSION

⚠ WARNING: Explosions from fuel vapors can cause injury or death!

- All fuel vapors are highly explosive. Use extreme care when handling and storing fuels. Store fuel in a well-ventilated area away from spark-producing equipment and out of the reach of children.
- Do not fill the fuel tank(s) while the engine is running.
- Shut off the fuel service valve at the engine when servicing the fuel system. Take care in catching any fuel that might spill. DO NOT allow any smoking, open flames, or other sources of fire near the fuel system or engine when servicing. Ensure proper ventilation exists when servicing the fuel system.
- Do not alter or modify the fuel system.
- Be sure all fuel supplies have a positive shutoff valve.
- Be certain fuel line fittings are adequately tightened and free of leaks.
- Make sure a fire extinguisher is installed nearby and is properly maintained. Be familiar with its proper use. Extinguishers rated ABC by the NFPA are appropriate for all applications encountered in this environment.

ACCIDENTAL STARTING

⚠ WARNING: Accidental starting can cause injury or death!

- To prevent accidental starting when servicing the generator, remove the 8 amp fuse from the control panel.
- Disconnect the battery cables before servicing the engine/generator. Remove the negative lead first and reconnect it last.
- Make certain all personnel are clear of the engine before starting.
- Make certain all covers, guards, and hatches are re-installed before starting the engine.

SAFETY INSTRUCTIONS

BATTERY EXPLOSION

⚠ WARNING: Battery explosion can cause injury or death!

- Do not smoke or allow an open flame near the battery being serviced. Lead acid batteries emit hydrogen, a highly explosive gas, which can be ignited by electrical arcing or by lit tobacco products. Shut off all electrical equipment in the vicinity to prevent electrical arcing during servicing.
- Never connect the negative (-) battery cable to the positive (+) connection terminal of the starter solenoid. Do not test the battery condition by shorting the terminals together. Sparks could ignite battery gases or fuel vapors. Ventilate any compartment containing batteries to prevent accumulation of explosive gases. To avoid sparks, do not disturb the battery charger connections while the battery is being charged.
- Avoid contacting the terminals with tools, etc., to prevent burns or sparks that could cause an explosion. Remove wristwatch, rings, and any other jewelry before handling the battery.
- Always turn the battery charger off before disconnecting the battery connections. Remove the negative lead first and reconnect it last when disconnecting the battery.

BATTERY ACID

⚠ WARNING: Sulfuric acid in batteries can cause severe injury or death!

- When servicing the battery or checking the electrolyte level, wear rubber gloves, a rubber apron, and eye protection. Batteries contain sulfuric acid which is destructive. If it comes in contact with your skin, wash it off at once with water. Acid may splash on the skin or into the eyes inadvertently when removing electrolyte caps.

⚠ WARNING: Carbon monoxide (CO) is a deadly gas!

- Ensure that the exhaust system is adequate to expel gases discharged from the engine. Check the exhaust system regularly for leaks and make sure the exhaust manifolds are securely attached and no warping exists. Pay close attention to the manifold, water injection elbow, and exhaust pipe nipple.
- Be sure the unit and its surroundings are well ventilated.
- In addition to routine inspection of the exhaust system, install a **carbon monoxide detector**. Consult your boat builder or dealer for installation of approved detectors.

⚠ WARNING: Carbon monoxide (CO) is an invisible odorless gas. Inhalation produces flu-like symptoms, nausea or death!

- Do not use copper tubing in diesel exhaust systems. Diesel fumes can rapidly destroy copper tubing in exhaust systems. Exhaust sulfur causes rapid deterioration of copper tubing resulting in exhaust/water leakage.
- Do not install exhaust outlet where exhaust can be drawn through portholes, vents, or air conditioners.
- Although diesel engine exhaust gases are not as toxic as exhaust fumes from gasoline engines, carbon monoxide gas is present in diesel exhaust fumes. Some of the symptoms or signs of carbon monoxide inhalation or poisoning are:
 - Vomiting
 - Dizziness
 - Throbbing in temples
 - Muscular twitching
 - Intense headache
 - Weakness and sleepiness

AVOID MOVING PARTS

⚠ WARNING: Rotating parts can cause injury or death!

- Do not service the engine while it is running. If a situation arises in which it is absolutely necessary to make operating adjustments, use extreme care to avoid touching moving parts and hot exhaust system components.
- Do not wear loose clothing or jewelry when servicing equipment; tie back long hair and avoid wearing loose jackets, shirts, sleeves, rings, necklaces or bracelets that could be caught in moving parts.
- Make sure all attaching hardware is properly tightened. Keep protective shields and guards in their respective places at all times.
- Do not check fluid levels or the drive belt's tension while the engine is operating.

HAZARDOUS NOISE

⚠ WARNING: High noise levels can cause hearing loss!

- Never operate an engine without its muffler installed.
- Do not run an engine with the air intake (silencer) removed.
- Do not run engines for long periods with their enclosures open.

⚠ WARNING: Do not work on machinery when you are mentally or physically incapacitated by fatigue!

SAFETY INSTRUCTIONS

OPERATORS MANUAL

Many of the preceding safety tips and warnings are repeated in your Operators Manual along with other cautions and notes to highlight critical information. Read your manual carefully, maintain your equipment, and follow all safety procedures.

GASOLINE ENGINE AND GENERATOR INSTALLATIONS

Preparations to install a gasoline engine or generator should begin with a thorough examination of the American Boat and Yacht Council's (ABYC) standards. These standards are from a combination of sources including the USCG and the NFPA.

Sections of the ABYC standards of particular interest are:

H-2 Ventilation
H-24 Gasoline Fuel Systems
P-1 Exhaust Systems
P-4 Inboard Engines
E-9 DC Electrical Systems

All installations must comply with the Federal Code of Regulations (FCR).

ABYC, NFPA AND USCG PUBLICATIONS FOR INSTALLING DIESEL ENGINES

Read the following ABYC, NFPA and USCG publications for safety codes and standards. Follow their recommendations when installing your engine.

ABYC (American Boat and Yacht Council)
"Safety Standards for Small Craft"

Order from:

ABYC
3069 Solomon's Island Rd.
Edgewater, MD 21037

NFPA (National Fire Protection Association)
"Fire Protection Standard for Motor Craft"

Order from:

NFPA
11 Tracy Drive
Avon Industrial Park
Avon, MA 02322

USCG (United States Coast Guard)
"USCG 33CFR183"

Order from:

U.S. Government Printing Office
Washington, D.C. 20404

INSTALLATION

When installing WESTERBEKE engines and generators it is important that strict attention be paid to the following information:

CODES AND REGULATIONS

Strict federal regulations, ABYC guidelines, and safety codes must be complied with when installing engines and generators in a marine environment.

SIPHON-BREAK

For installations where the exhaust manifold/water injected exhaust elbow is close to or will be below the vessel's waterline, provisions must be made to install a siphon-break in the raw water supply hose to the exhaust elbow. This hose must be looped a minimum of 20" above the vessel's waterline. *Failure to use a siphon-break when the exhaust manifold injection port is at or below the load waterline will result in raw water damage to the engine and possible flooding of the boat.*

If you have any doubt about the position of the water-injected exhaust elbow relative to the vessel's waterline under the vessel's various operating conditions, *install a siphon-break.*

NOTE: *A siphon-break requires periodic inspection and cleaning to ensure proper operation. Failure to properly maintain a siphon-break can result in catastrophic engine damage. Consult the siphon-break manufacturer for proper maintenance.*

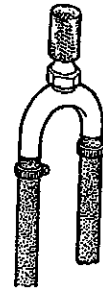

AVAILABLE FROM
YOUR WESTERBEKE
DEALER

EXHAUST SYSTEM

The exhaust hose must be certified for marine use. The system must be designed to prevent water from entering the exhaust under any sea conditions and at any angle of the vessels hull.

A detailed Marine Installation Manual covering gasoline and diesel engines and generators is supplied with every unit sold. This manual is also available in pdf format on our website to download

Website: www.westerbeke.com

TABLE OF CONTENTS

Introduction	2	Digital Control Box	41
Engine Troubleshooting	3	7.6/5.7KW Wiring Diagram	42
Testing for Overhaul	7	Specifications - 7.6/5.7KW	43
Engine Disassembly	8	Specifications - 5.5/5.0KW	44
Cylinder Head	10	Generator Information	45
Valve and Valve Spring Inspection	11	7.6/5.7 EDT Generator Single Phase	46
Valve Installation/Valve Clearance	12	Troubleshooting	47
Gear Case/Governor	13	No-Load Voltage Adjustment	48
Timing Gear	14	Residual Voltage Check	49
Camshaft	14	Bridge Rectifier	50
Piston and Connecting Rod	15	Exciter/Rotor Field	51
Crankshaft	17	Measuring Resistance	52
Cylinder Block	19	Shore Power Transfer Switch	53
Governor System	20	5.5/5.0 EDC Generator Single Phase	54
Engine Assembly	22	Troubleshooting	55
Exhaust Manifold	24	Dual Exciter No-Load Voltage Adjustment	56
Heat Exchanger	24	Single Exciter No-Load Voltage Adjustment	57
Fuel Injection Pump	25	Integral Controller	58
Fuel Lift Pump/Injection Timing	26	Testing the Battery Charging Circuit	58
Fuel Injectors	27	Testing the Exciter Windings	59
Glow Plugs	29	Field-Testing Capacitors	59
Coolant Circulating Pump	30	Shore Power Transfer Switch	60
Raw Water Pump	31	Testing Component Resistance Values	61
Starter Motor	32	Special Tools	62
Oil Pressure	36	Service Data/Tolerances & Limits	63
Engine Adjustments	37	Torque Specifications	65
Alternator Testing/Troubleshooting	38	Standard Hardware Torques	66
		Metric Conversions	67
		Index	68

INTRODUCTION

PRODUCT SOFTWARE

Product software (tech data, parts lists, manuals, brochures and catalogs) provided from sources other than WESTERBEKE are not within WESTERBEKE'S control.

WESTERBEKE CANNOT BE RESPONSIBLE FOR THE CONTENT OF SUCH SOFTWARE, MAKES NO WARRANTIES OR REPRESENTATIONS WITH RESPECT THERETO, INCLUDING ACCURACY, TIMELINESS OR COMPLETENESS THEREOF AND WILL IN NO EVENT BE LIABLE FOR ANY TYPE OF DAMAGE OR INJURY INCURRED IN CONNECTION WITH OR ARISING OUT OF THE FURNISHING OR USE OF SUCH SOFTWARE. WESTERBEKE customers should also keep in mind the time span between printings of WESTERBEKE product software and the unavoidable existence of earlier WESTERBEKE manuals. Product software provided with WESTERBEKE products, whether from WESTERBEKE or other suppliers, must not and cannot be relied upon exclusively as the definitive authority on the respective product. It not only makes good sense but is imperative that appropriate representatives of WESTERBEKE or the supplier in question be consulted to determine the accuracy and currentness of the product software being consulted by the customer.

NOTES, CAUTIONS AND WARNINGS

As this manual takes you through the disassembly, inspection and assembly procedure of your engine/generator, critical information will be highlighted by NOTES, CAUTIONS, and WARNINGS. An explanation follows:

NOTE: *An operating procedure essential to note.*

CAUTION: *Procedures, which if not strictly observed, can result in the damage or destruction of your engine/generator.*

WARNING: *Procedures, which if not properly followed, can result in personal injury or loss of life.*

ORDERING PARTS

Whenever replacement parts are needed, always provide the generator model number, engine serial number, and generator serial number as they appear on the silver and black name-plate located on the generator end. You must provide us with this information so we may properly identify your engine/generator. In addition, include a complete part description and part number for each part needed (see the separately furnished Parts List). Also insist upon WESTERBEKE packaged parts because will fit or generic parts are frequently not made to the same specifications as original equipment.

CUSTOMER IDENTIFICATION CARD



Customer Identification
WESTERBEKE OWNER
MAIN STREET
HOMETOWN, USA
Model 7.6KW Ser. #
Expires

SERIAL NUMBER LOCATION

The engine and generator serial numbers and model numbers are located on a decal on the generator housing. The engine serial number can also be found stamped into the engine block just above the injection pump. The generator serial number is stamped into the generator housing on the flat surface on the left side of the generator.

An identification plate on the engine manifold also displays the engine model and serial number.

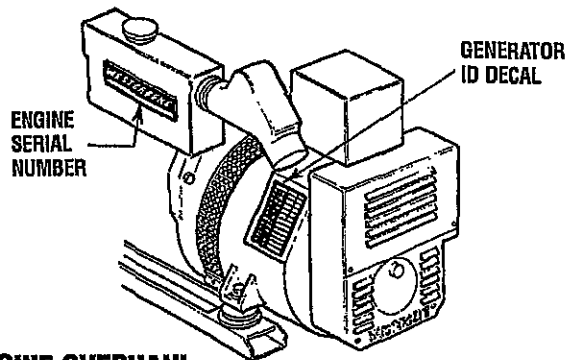

ENGINE OVERHAUL

The following sections contain detailed information relating to the proper operation characteristics of the major components and systems of the engine. Included are disassembly, inspection and reassembly instructions for the guidance of suitable equipped and staffed marine engine service and rebuilding facilities. The necessary procedures should be undertaken only by such facilities.

Additional detailed information and specifications are provided in other sections of this manual, covering the generator, alternator, starter motor, engine adjustments, cooling pumps, etc.

ENGINE TROUBLESHOOTING

The following troubleshooting chart describes certain problems relating to engine service, the probable causes of these problems, and the recommendations to overcome these problems. This chart may be of assistance in determining the need for an engine overhaul.

NOTE: The engine's electrical system is protected by a 20-ampere manual reset circuit breaker. The preheat solenoid is mounted on the same bracket.

PROBLEM	PROBABLE CAUSE	VERIFICATION/REMEDY
HARD STARTING	LOW CRANKING SPEED 1. Engine oil viscosity too-high. 2. Run-down battery. 3. Worn battery. 4. Battery terminals loosely connected. 5. Defective starter.	1. Replace engine oil with less viscous oil. 2. Recharge battery. 3. Replace battery. 4. Clean terminals and correct cables. 5. Repair or replace starter.
	DEFECTIVE INJECTION SYSTEM 1. Air trapped in fuel passage. 2. Clogged fuel filter. 3. Low injection pressure. 4. Inadequate spray. 5. Injection pump delivering insufficient fuel. 6. Injection too early.	1. Bleed air from fuel system. 2. Clean or replace filter. 3. Adjust injection pressure. 4. Clean or replace nozzle. 5. Repair or replace injection pump. 6. Adjust injection timing.
	MAIN ENGINE TROUBLES 1. Low compression. a. Incorrect valve clearance. b. Inadequate contact of valve seat. c. Valve stem seized. d. Broken valve spring. e. Compression leaks through cylinder head gasket. f. Piston ring seized. g. Worn piston ring and cylinder. 2. Burnt glow plug. 3. Faulty glow plug operation.	a. Adjust valve clearance. b. Lap valve. c. Replace valve and valve guide. d. Replace valve spring. e. Replace gasket. f. Replace piston and piston ring. g. Overhaul engine. 2. Replace glow plug. 3. Correct lead wire connection.
LOW OUTPUT POWER	LOW COMPRESSION	See HARD STARTING
	INJECTION SYSTEM OUT OF ADJUSTMENT 1. Incorrect injection timing. 2. Insufficient injection. 3. Low injection pressure.	1. Adjust injection timing. 2. Repair or replace injection pump. 3. Check injection nozzle and adjust pressure.
	INSUFFICIENT FUEL 1. Air trapped in fuel system. 2. Clogged filter. 3. Contaminated fuel tank.	1. Check and retighten connector. 2. Clean or replace filter. 3. Clean tank.
	INSUFFICIENT INTAKE AIR 1. Air intake obstructed.	1. Clean intake.

(continued)

ENGINE TROUBLESHOOTING

PROBLEM	PROBABLE CAUSE	VERIFICATION/REMEDY
EXCESSIVE OIL CONSUMPTION	OVERHEATING 1. Low coolant level. 2. Loose V-belt. 3. Incorrect injection timing. 4. Low engine oil level.	1. Add coolant. 2. Adjust or replace V-belt. 3. Adjust injection timing. 6. Add engine oil.
	OIL LEAKAGE 1. Defective oil seals. 2. Broken gear case gasket. 3. Loose gear case attaching bolts. 4. Loose oil drain hose. 5. Loose oil pipe connector. 6. Broken rocker cover gasket. 7. Loose rocker cover attaching bolts.	1. Replace oil seals. 2. Replace gasket. 3. Retighten bolts. 4. Retighten connections. 5. Retighten oil connections. 6. Replace gasket. 7. Retighten attaching bolts.
	OIL LEVEL RISING 1. Incorrectly positioned piston ring gaps. 2. Displaced or twisted connecting rod. 3. Worn piston ring. 4. Worn piston or cylinder.	1. Correct ring gap positions. 2. Replace connecting rod. 3. Replace ring. 4. Replace piston and rebore cylinder.
EXCESSIVE FUEL CONSUMPTION	OIL LEVEL FALLING 1. Defective stem seal. 2. Worn valve and valve guide.	1. Replace stem seal. 4. Replace a valve and valve guide.
	ENGINE BODY TROUBLES 1. Noisy knocking. 2. Smoky exhaust. 3. Moving parts nearly seized or excessively worn. 4. Poor compression. 5. Improper valve timing. 6. Improper valve clearance.	1. See <i>KNOCKING</i> . 2. See <i>SMOKY EXHAUST</i> . 3. Repair or replace. 4. See <i>LOW COMPRESSION; HARD STARTING</i> . 5. Adjust. 6. Adjust.
	INSUFFICIENT INTAKE AIR 1. Air intake obstructed.	1. Remove obstruction.
	NOZZLE TROUBLES 1. Seized nozzle. 2. Worn nozzle.	1. Replace. 2. Replace.
	IMPROPER FUEL FUEL LEAKS	Replace with proper fuel. Find fuel leaks.
SMOKY EXHAUST	WHITISH OR PURPLISH 1. Excessive engine oil. 2. Excessive rise of oil into combustion chamber. a. Poor piston contact. b. Seized piston ring. c. Excessive piston-to-cylinder clearance.	1. Correct oil level. a. Check. b. Replace or clean. c. Replace or correct.

(continued)

ENGINE TROUBLESHOOTING

PROBLEM	PROBABLE CAUSE	VERIFICATION/REMEDY
SMOKY EXHAUST (cont.)	WHITISH OR PURPLISH (cont.) d. Worn valve stem and valve guide. e. Low engine oil viscosity. f. Excessive oil pressure. 3. Injection timing is too late. 4. Insufficient compression.	d. Replace. e. Replace. f. Correct. 3. Adjust. 4. See <i>LOW COMPRESSION; HARD STARTING</i> .
	BLACKISH OR DARK GRAYISH 1. Engine body troubles. a. Poor compression. b. Improper valve clearance. 2. Insufficient intake air. 3. Improper fuel.	a. See <i>LOW COMPRESSION; HARD STARTING</i> . b. Adjust. 2. Clean air inlet. 3. Replace with proper fuel.
ABNORMAL SOUND OR NOISE	CRANKSHAFT AND MAIN BEARING 1. Badly worn bearing. 2. Badly worn crankshaft. 3. Melted bearing.	1. Replace bearing and grind crankshaft. 2. Grind crankshaft. 3. Replace bearing and check lubrication system.
	CONNECTING ROD AND CONNECTING ROD BEARING 1. Worn connecting rod big end bearing. 2. Worn crankpin. 3. Bent connecting rod.	1. Replace bearing. 2. Grind crankshaft. 3. Correct bend or replace.
	PISTON, PISTON PIN, AND PISTON RING 1. Worn cylinder. 2. Worn piston pin. 3. Piston seized. 4. Piston seized and ring worn or damaged.	1. Rebore cylinder to oversize and replace piston. 2. Replace piston. 3. Replace piston and rebore cylinder. 4. Replace piston and rings.
	VALVE MECHANISM 1. Worn camshaft. 2. Excessive valve clearance. 3. Worn timing gear. 4. Worn fan pulley bearing.	1. Replace. 2. Adjust. 3. Replace. 4. Replace.
ROUGH OPERATION	INJECTION PUMP SYSTEM 1. Uneven injection. 2. Control rack malfunctioning. 3. Worn delivery valve. 4. Inadequate injection nozzle spray.	1. Adjust injection or replace parts. 2. Disassemble, check and correct injection pump. 3. Replace. 4. Replace injection nozzle.
	GOVERNING SYSTEM 1. Governor lever malfunctioning. 2. Fatigued governor spring.	1. Check governor shaft and correct operation. 2. Replace.

(continued)

ENGINE TROUBLESHOOTING

PROBLEM	PROBABLE CAUSE	VERIFICATION/REMEDY
KNOCKING	ENGINE KNOCKS WITHOUT MUCH SMOKE 1. Main engine troubles. a. Overheated cylinder. b. Carbon deposits in cylinder. 2. Too early injection timing. 3. Too high injection pressure. 4. Improper fuel.	a. See <i>OVERHEATING; LOW OUTPUT</i> . b. Clean. 2. Correct. 3. Correct. 4. Replace with proper fuel.
	KNOCKING WITH DARK SMOKE 1. Poor compression. 2. Injection pump malfunctioning. a. Worn plunger. b. Pinion is not in mesh with control rack. c. Broken delivery valve spring. d. Worn delivery valve seat. 3. Improper nozzle. a. Poor spray. b. Poor chattering. c. After-injection drip. d. Nozzle needle valve seized.	1. See <i>LOW COMPRESSION; HARD STARTING</i> . a. Replace. b. Correct. c. Replace. d. Replace. a. Clean or replace nozzle. b. Repair or replace nozzle. c. Repair or replace nozzle. d. Replace.
INTERMITTENT EXHAUST SOUND	1. Fuel filter clogged. 2. Fuel pipe sucks air. 3. Water mixed in fuel	1. Clean or replace. 2. Retighten pipe joints or replace pipe. 3. Replace fuel.
OVERHEATING	1. V-belt slackening or slippery with oil. 2. Damaged water pump. 3. Lack of coolant. 4. Low oil level or poor oil quality. 5. Knocking. 6. Moving parts seized or damaged. 7. Defective thermostat.	1. Adjust, replace or clean. 2. Replace. 3. Add. 4. Add or change. 5. See <i>KNOCKING</i> . 6. Replace. 7. Replace.
LOW OIL PRESSURE	1. Worn Bearings. 2. Relief valve malfunction. 3. Clogged oil cooler. 4. Diesel dilution of the oil.	1. Engine overhaul replace bearings. 2. Overhaul oil pump. 3. Repair. 4. Injection pump repair.

(continued)

ENGINE TROUBLESHOOTING

PROBLEM	PROBABLE CAUSE	VERIFICATION/REMEDY
LCD DISPLAY FAULTS	<ol style="list-style-type: none"> 1. Check battery. 2. 20 amp breaker off. 3. Loose display connection. 4. 1 amp fuse blown (faulty). 	<ol style="list-style-type: none"> 1. Battery on. 2. Turn breaker off. 3. Check all cable connections. 4. Check/replace. Determine cause.
LOW OIL PRESSURE	<ol style="list-style-type: none"> 1. Oil level low/oil leak. 2. Lack of oil pressure. 3. Ground connection. 4. Faulty control module (ECU). 5. Faulty oil pressure sensor. 	<ol style="list-style-type: none"> 1. Check oil level, add oil and repair leaks. 2. Test oil pressure. If OK, test oil pressure sensor, inspect oil filter, inspect oil pump. 3. Check ground connection. 4. Inspect all the plug connections/replace. 5. Check sensor/replace.
HIGH COOLANT TEMPERATURE	<ol style="list-style-type: none"> 1. Check system coolant level. 2. Sea water pump. 3. Check water pump drive belt. 4. Faulty temperature sensor. 5. Ground connection. 6. Faulty control module (ECU). 	<ol style="list-style-type: none"> 1. Add coolant. Check for leaks. 2. Inspect impeller/pump/replace. 3. Adjust belt tension, replace belt. 4. Check sensor/replace. 5. Check ground circuit. 6. Check plug connections/replace.
HIGH EXHAUST TEMPERATURE	<ol style="list-style-type: none"> 1. Check sea water flow. 2. Faulty exhaust temperature switch. 3. Ground connection. 4. Faulty control module (ECU). 5. Sea water pump. 6. Faulty fire suppression system. 	<ol style="list-style-type: none"> 1. Inspect thru hull fitting, hose and strainer. Correct as needed. 2. Test/replace. 3. Check ground circuit. 4. Check plug connections. 5. Inspect impeller/replace. 6. By-pass system/check.
BATTERY VOLTAGE	<ol style="list-style-type: none"> 1. Check alternator drive belt. 2. Check charge voltage. 3. Check battery connections. 4. Faulty control module (ECU). 	<ol style="list-style-type: none"> 1. Adjust tension/replace if worn. 2. Check excitation. Replace/repair alternator. 3. Check + and - cables from battery to engine. 4. Check plug connections/replace.
GENERATOR FREQUENCY Overspeed (steady LED) Underspeed (flashing LED)	<ol style="list-style-type: none"> 1. Check engine speed. 2. Check fuel supply. 3. Amperage load. 4. Crank cycle with no start. (underspeed fault) 	<ol style="list-style-type: none"> 1. Check speed setting. 2. Inspect filters/replace filters. Test fuel pump operation. 3. Check + and - cables from battery to engine. 4. Check cause for no start.
LED DISPLAY EDGES TURN PINK	<ol style="list-style-type: none"> 1. Compartment ambient temperature too high. 	<ol style="list-style-type: none"> 1. Ventilate compartment. <p>NOTE: Heat will often change the color of an LCD display. This will not effect the operation of the engine.</p>

TESTING FOR OVERHAUL

HOW TO DETERMINE ENGINE OVERHAUL PERIOD

Cause of Low Compression

Generally, the time at which an engine should be overhauled is determined by various conditions such as lowered engine power output, decreased compression pressure, and increased fuel and oil consumption. The lowered engine power output, in the case of diesel engines, is not necessarily due to trouble with the engine itself, but is sometimes caused by injector nozzle wear or injection pump wear. It is most reasonable to judge by a decrease in compression pressure. The decrease in compression pressure is caused by many factors. It is, therefore, necessary to determine a cause or causes on the basis of data produced by periodic inspection and maintenance. Oil analysis on a seasonal basis is a good means of monitoring engine internal wear. When caused by worn cylinders or piston rings, the following symptoms will occur:

- 1 Low engine power output
- 2 Increased fuel consumption
- 3 Increased oil consumption
- 4 Hard engine starting
- 5 Noisy engine operation

These symptoms often appear together. Symptoms (2) and (4) can result also from excessive fuel injection, improper injection timing, and wear of glow plugs and nozzles. They are caused also by defective electrical devices such as the battery, alternator, starter and glow plugs. Therefore it is desirable to judge the optimum engine overhaul time by the lowered compression pressure caused by worn cylinders and pistons plus increased oil consumption. Satisfactory combustion is obtained only under sufficient compression pressure. If an engine lacks compression pressure, incomplete combustion of fuel will take place even if other parts of the engine are operating properly. To determine the period of engine overhaul, it is important to measure the engine compression pressure regularly. At the same time, the engine speed at which the measurement of compression pressure is made should be checked because the compression pressure varies with engine rpm. The engine rpm can be measured at the front end of the crankshaft.

NOTE: To test engine compression see the ENGINE ADJUSTMENT section of this manual.

OVERHAUL CONDITIONS

Compression pressure tends to increase a little in a new engine until piston rings and valve seats have been broken in. Thereafter, it decreases gradually with the progress of wear of these parts.

When decrease of compression pressure reaches the repair limit, the engine must be overhauled.

The engine requires overhaul when oil consumption is high, blowby evident, and compression valves are at minimum or below. *Engine compression should be 398 psi, 28 kg/cm² at 280 rpm.*

Precautions for Disassembly and Reassembly

When servicing an engine, keep in mind the following precautions.

Disassembly

1. Before disassembly and cleaning, carefully check for defects which cannot be found after disassembly and cleaning.
2. Drain water, fuel and oil before disassembly.
3. Clean or wash the engine exterior.
4. Do not remove or disassemble parts that do not require disassembly.
5. Perform disassembly in a proper order using proper tools. Keep disassembled parts in order. Apply oil when necessary. Take special care to keep the fuel system parts from intrusion of dust and dirt.

Reassembly

1. Carefully check gaskets, packings and oil seals even if checking is not specified. Replace with new ones if defective.
2. Be sure to install components in proper directions and positions. (Pay attention to dowel pins, mating marks and specified directions.) Where tightening torque is not specified, tighten evenly to an ordinary torque. Apply sealant where specified.
3. After completion of reassembly, recheck for any abnormalities. Prepare for starting the engine, and idle the engine sufficiently for a test run.

PRECAUTIONS

- Be careful not to mix bolts and nuts. Metric and S.A.E. bolts are used on various engine assemblies.
- During assembly, recheck clearances and insure that parts are being assembled in their proper order and facing in the correct direction in relation to the engine block, such as, pistons, piston rings, bearings and bearing caps.
- Apply lubricating oil to moving parts during assembly. Insure that moving parts, when assembled on the engine, rotate or slide and are not subject to binding or excessive tension.
- If there are mating marks scribed during disassembly, reference them correctly for assembly..
- Use new gaskets, lockwashers, o-rings, etc.
- Tighten the bolts and nuts on important parts of engine to specified torques using a reliable torque wrench.
- Use liquid sealants when required on nuts, bolts and gaskets. Refrain from using tape sealants.

ASSEMBLY INFORMATION

Be aware of these common problems that can occur during reassembly.

Insufficient Lubrication. Heavily oil sliding and reciprocating parts, lightly oil head bolts and other fasteners, except those that penetrate into the water jacket. These fasteners should be sealed with Permatex No. 2 or the high-tech equivalent.

Reversed Orientation. Most gaskets, many bolt washers, and all thermostats are symmetrical.

Mechanical Damage. Run fasteners down in approved torque sequences and in three steps - 1/2, 2/3, and 1/1 torque. Exceptions are torque-to-yield bolts and rocker arm shaft fasteners. The former are torqued as indicated. The latter-rocker shaft fasteners- should be brought down in very small increments, working from the center bolts out. Gaskets, especially head gaskets, might also be damaged during assembly, and should be positioned with great care

Service Manual

The engine that powers the 7.6Kw/5.7Kw BTD Generator also is used to power the 5.0Kw/4.0Kw BCD generator. This 3 cylinder diesel engine has gone through several model designations but it is essentially the same engine internally.

The engine overhaul data, including the tolerance standards and limits are the same for both generators throughout this manual (the exceptions being the cylinder bore and piston diameter). The GENERATOR SECTION covers both the BTD and BCD back ends.

ENGINE DISASSEMBLY

GENERATOR

Disconnect ground wires, battery cable connections and incoming and return fuel lines.

Disconnect the AC wiring and unplug the DC wiring harness. Separate the the exhaust hose at the water injected elbow.

Carefully support and then unbolt the generator back end from the engine.

See SPECIAL TOOLS - GENERATOR.

With the generator separated from the engine begin the following step by step procedure of engine disassembly.

Drain the engine oil and coolant from the engine and heat exchanger.

Remove the generator/engine wiring harness in its entirety. Label the terminal connections to ensure proper reattachment.

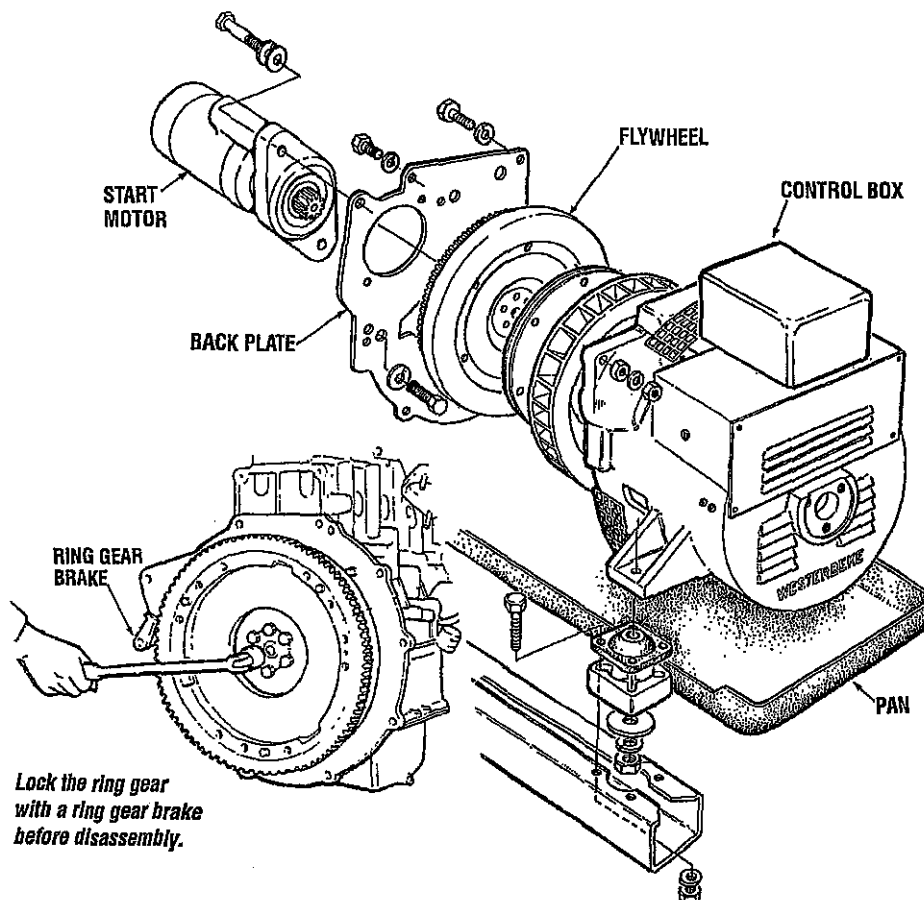

Lock the ring gear with a ring gear brake before disassembly.

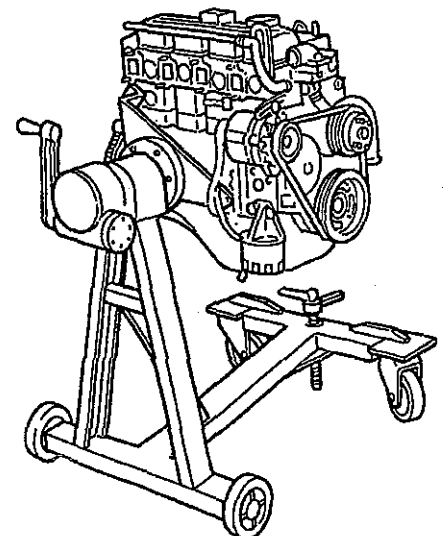
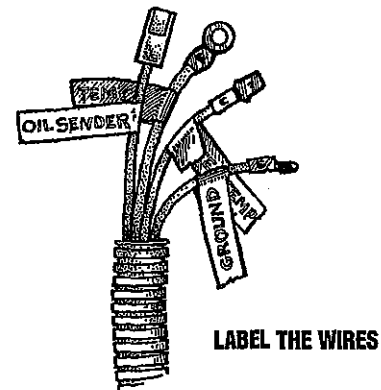

The engine should be securely mounted on a suitable engine stand.

WESTERBEKE
Engines & Generators

ENGINE DISASSEMBLY

1. Remove engine heat exchanger. If possible, leave one end of each hose connection attached to the part being removed. For maintenance, see HEAT EXCHANGER.
2. Remove the starter motor. For starter motor repair, see STARTER MOTOR.
3. Remove flywheel.
4. Remove engine backing plate.
5. Unbolt elbows at head and remove the exhaust manifold in its entirety. See EXHAUST MANIFOLD.
6. Remove the engine alternator and raw water pump.
7. Remove the engine mounted fuel filter and fuel line to injection pump. (Note the arrangement of sealing washers on banjo bolts at fuel filter and injection pump.)
8. Remove the thermostat housing and the thermostat. Leave temperature sending unit in place.
9. Remove the coolant circulating pump.
10. Remove the air intake silencer.

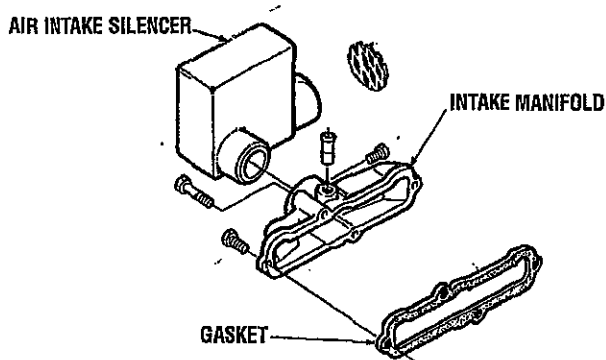

Now the basic engine is ready for disassembly, cleaning, and repair if necessary.

1. Remove the high pressure injector line assembly. When disconnecting each injector line from the injection pump side delivery valve holder, grasp the holder with a wrench to prevent it from loosening. After removing the pipe assembly, plug the nozzle holders and delivery valve holders to prevent intrusion of dust.
2. Disconnect the glow plug lead wire.
3. Loosen the fresh water pump drive belt and dismount the belt, idler pulley and bracket.
4. Disconnect the air breather hose.

CYLINDER HEAD REMOVAL

5. Remove the rocker cover.
6. Remove the rocker shaft assembly.
7. Loosen the cylinder head mounting bolts equally and gradually in the numerical order as illustrated and remove the cylinder head assembly (including the exhaust manifold).

SEQUENCE FOR LOOSENING CYLINDER HEAD BOLTS

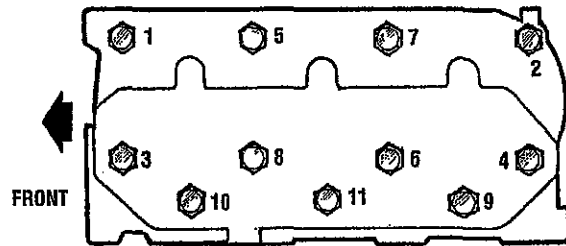

8. Lift the cylinder head off the engine.
9. Remove the cylinder head gasket. Clean the cylinder head and the cylinder block surface from which the gasket has been removed.
10. Remove the injector assemblies and glow plugs from the cylinder head.
11. Remove the exhaust manifold from the cylinder head.
12. Remove the valve retainers, valve springs and valves from the cylinder head. When removing each valve retainer, depress the retainer against the valve spring and remove the retainer lock. Identify each valve by putting a mark indicating the number of the cylinder from which the valve is removed.
13. Remove the valve stem seals.

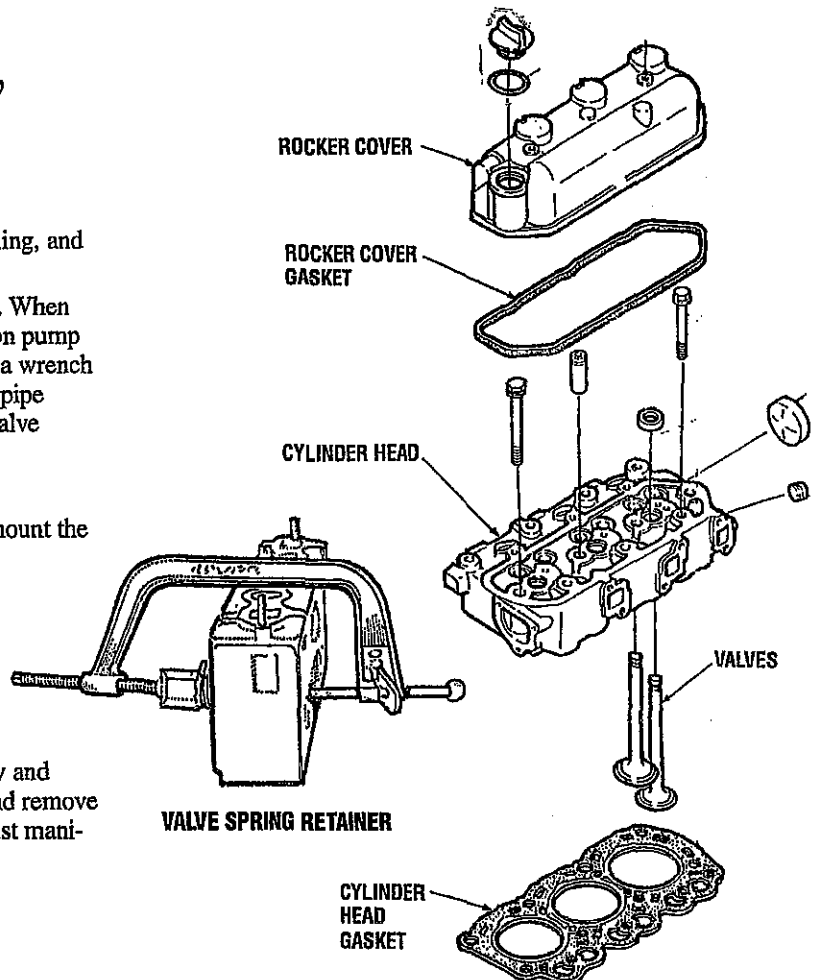

CYLINDER HEAD

Cylinder Head Inspection

Clean the cylinder and the cylinder block surface from which the gasket has been removed. Carefully check the cylinder head for cracks or any other damage as shown below. Use a straightedge and a thickness gauge to check the surface for distortion and warpage.

Check the valve guides and valve contact surfaces.

Cylinder head distortion repair limit: 0.004 in (0.1 mm)

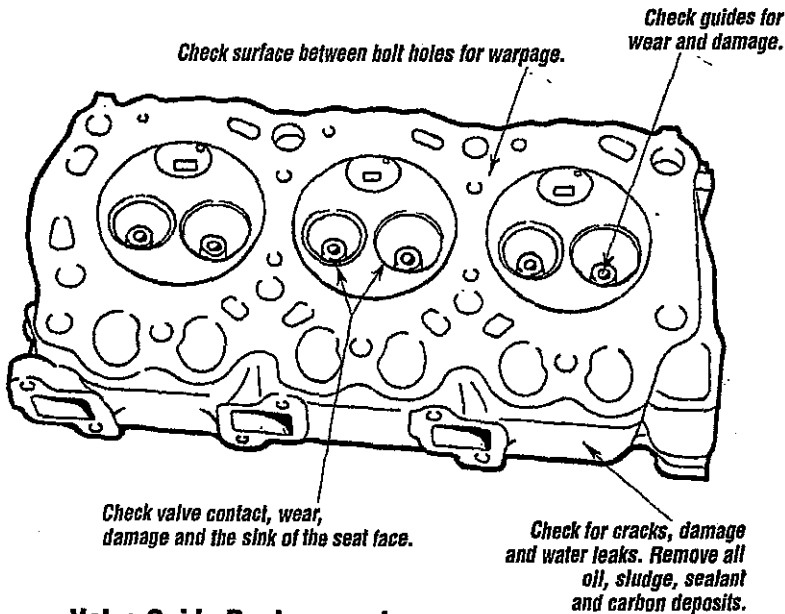

Valve Seat Repair

If a valve seat is found defective, reface it or have a machine shop install a new seat.

Sinkage of valve
Standard 0.019in (0.5mm)
Limit 0.059in (1.5mm)

NOTE: When checking valve sinkage, the valve guide must be in normal condition. Resurface the valve seat so that it contacts the mid-portion of the valve face.

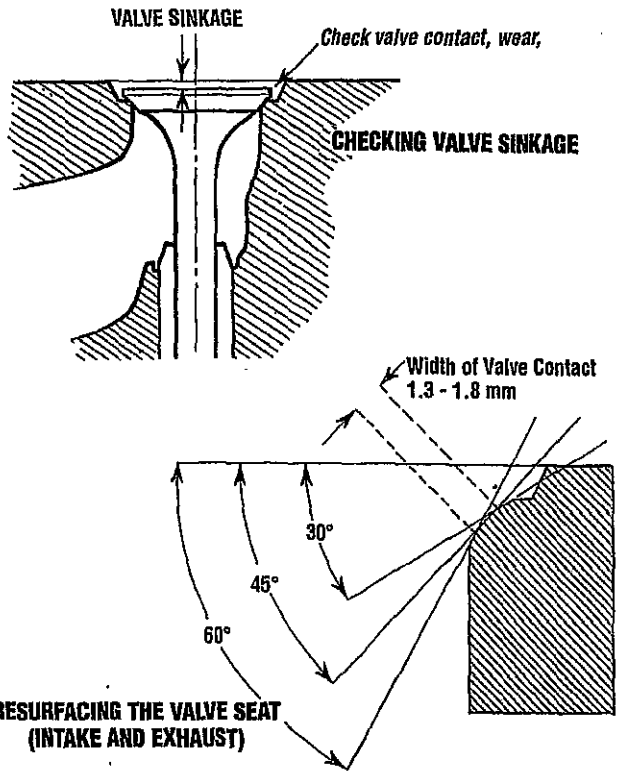

Valve Guide Replacement

If a valve guide is found defective, replace it.

1. Remove the valve guide by pressing at its upper end and pull it out to the valve seat side.
2. Install the valve guide by press fitting the guide from the upper side of the cylinder head to a height of 14mm (± 0.5) from the valve spring seat face.

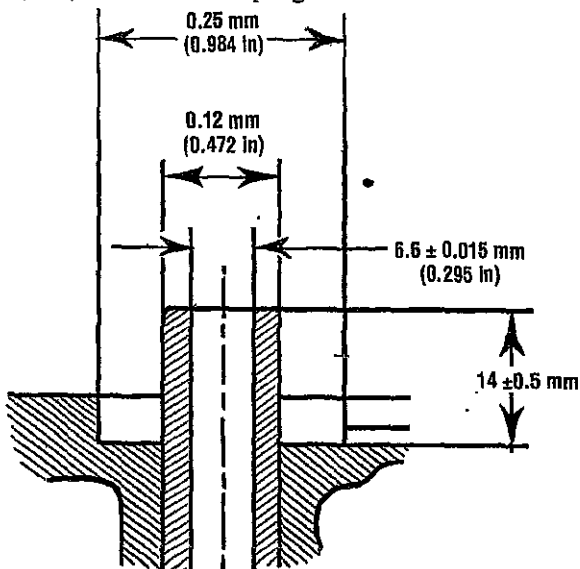

PRESS-FITTING THE VALVE GUIDE

Installing The Cylinder Head

Installation of the cylinder head is in the reverse order of removal. Pay attention to the following.

1. Renew the cylinder head gasket. No application of sealant is necessary. On the upper front of the gasket is the engine model to which the gasket is applicable. Be careful not to confuse it with a gasket for another engine model.
2. Tighten the cylinder head bolts in the numerical order shown going through that order two or three times. Tighten each bolt a little at a time until all are tightened to the specified torque.

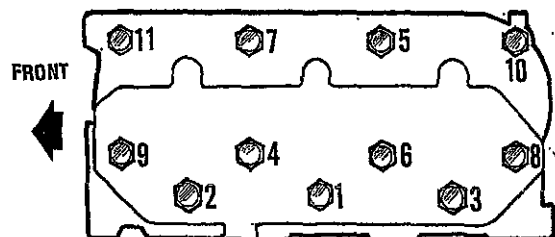

BOLT TIGHTENING SEQUENCE

VALVE AND VALVE SPRING INSPECTION

VALVE REMOVAL

1. Dismount the cylinder head assembly.
2. Depress the valve retainer (to compress the valve spring) and remove the retainer lock.

REMOVING VALVES

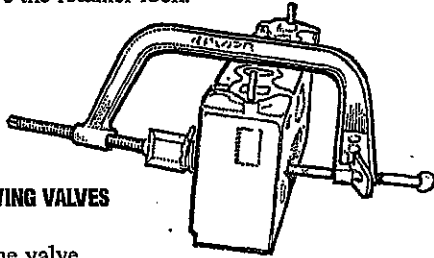

3. Remove the valve.
4. Inspect all the components and repair or replace any defective parts.

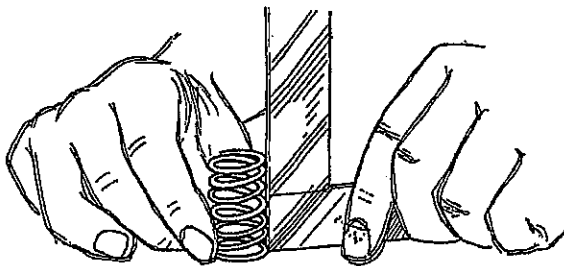
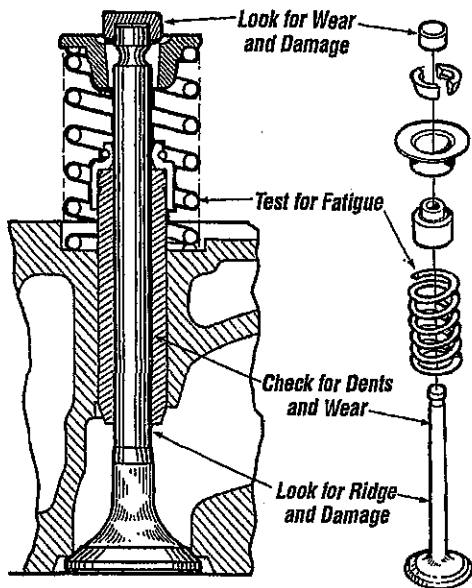

SQUARENESS CHECK

SQUARENESS GAUGE

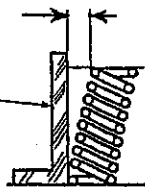

Squareness Check

Standard 2°
Limit 3°

Valve Spring Squareness Check. Check the squareness of the valve spring and, if it is more than the limit, replace the spring.

Valve Spring Fitting Pressure Check. Check the valve spring fitting pressure with a valve spring tester and, if the pressure is less than the limit, replace the spring.

Pressure (Load) Test
Standard 13.095 lbs/1.398 in (5.94 kg/35.5 mm)
Limit -15%

NOTE: Measure the fitting pressure after compressing the spring several times.

Valve Spring Free Length Check. Measure the free length of the valve spring and if the free length is less than the limit, replace it.

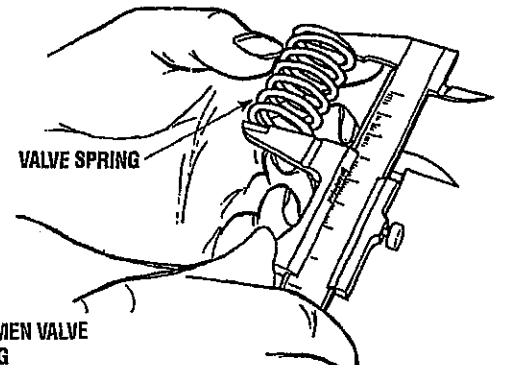
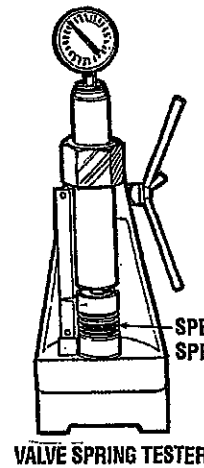

Free Length Test
Standard 1.595 in (40.5 mm)
Limit 1.5 in (39.3 mm)

Valve Inspection

Valve Stem Wear Inspection. If the valve stem is bent or its diameter is less than the standard, replace the valve.

Valve Stem
Standard 6.6 mm (0.260 in)
Margin
Standard 1.0 mm (0.039 in)
Limit 0.5 mm (0.019 in)

1. If the valve face is found worn down, resurface it with a valve refacer. If the margin of the resurfaced valve exceeds the service limit, replace the valve.
2. If the valve stem end has been indented by wear, flatten it with an oil stone.

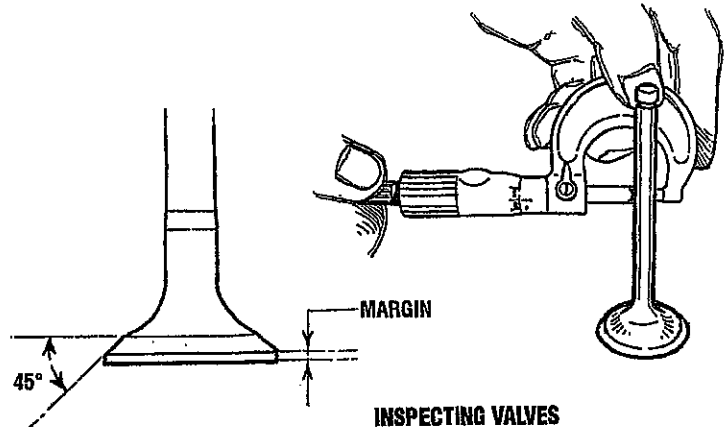

VALVE INSTALLATION / VALVE CLEARANCE

Installation

Install the valve and valve springs. Refer to the illustrations and callouts shown below.

NOTE: Be careful not to damage the spring and stem seal by excessively compressing the spring when installing the valve spring.

Mount the Cylinder Head Assembly and adjust the valve clearances.

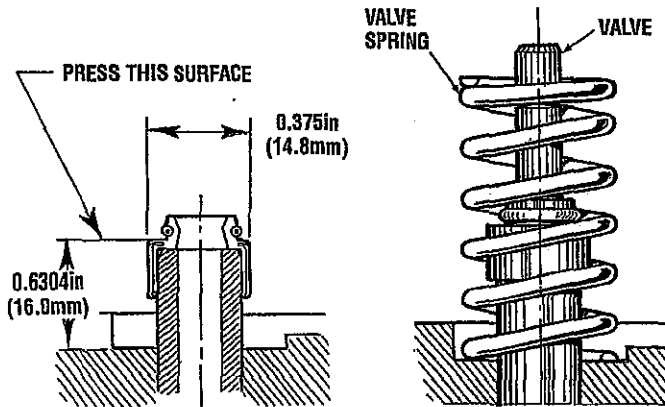

INSTALLING SPRING

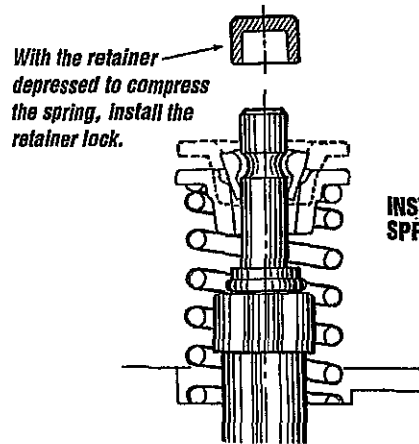

INSTALLING THE SPRING RETAINER

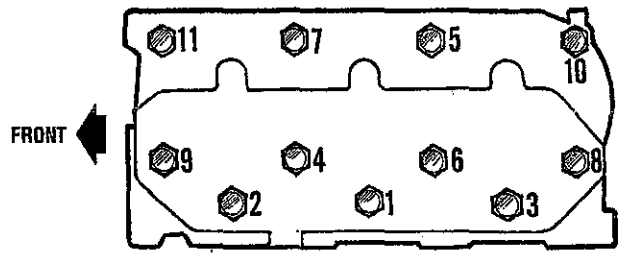

CYLINDER HEAD BOLT TIGHTENING SEQUENCE

NOTE: The Rocker Assembly (Rocker Arms, Shaft and Stays) are not in the engine when the cylinder head bolts are retightened in this procedure.

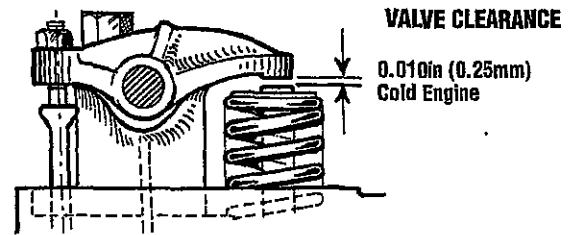

1. Set the cylinder to be adjusted to the Top Dead Center (T.D.C.) of the the compression stroke. Valve clearance: 0.010 in (0.25 mm) cold for both intake and exhaust valves.
2. The Top Dead Center of the compression stroke can be obtained by aligning the T.D.C. Mark (notch) on the crankshaft pulley with the mark on the gear case.
3. First align the T.D.C. mark for the No. 1 cylinder. Confirm that the valves do not move up and down when the crankshaft is turned 20° in the normal direction of rotation and in the reverse direction.
4. When setting the T.D.C. For the #3 and #2 cylinders, perform as follows. From the T.D.C. for the #1 cylinder, turn the crankshaft 240° clockwise to set the #3 cylinder T.D.C. Further, turn the crankshaft 240° clockwise to set the #2 cylinder to T.D.C.

Torquing The Cylinder Head Bolts

NOTE: Cylinder head bolts must be retightened before adjusting the valve clearances.

Tighten the cylinder head bolts according to the the sequence shown. Make sure the engine is cold when this is done. Before applying the specified torque to the bolt, loosen it 1/4 to 1/2 of a turn and then apply the torque. Follow this procedure according to the numbered sequence shown in the illustration.

- | | |
|--|---------------------------------|
| Bolts #1, 2, and 3
torque (12mm socket) | 14 - 22 ft-lb (2.0 - 3.0 kg-m). |
| Bolts #4, 5, 6, 7, 8, 9, 10 and 11
torque (14mm socket) | 54 - 61 ft-lb (7.5 - 8.5 kg-m). |
| Rockershaft Hold Down Bolts
torque (12mm socket) | 11 - 16 ft-lb (1.5 - 2.2 kg-m). |

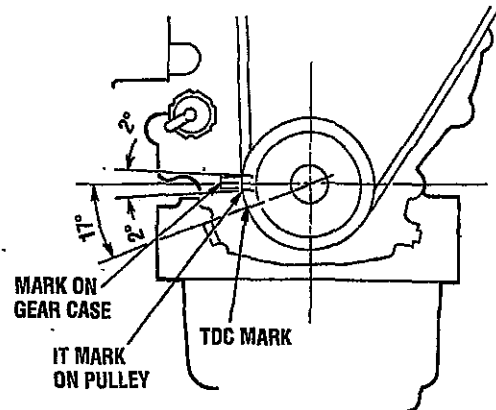

GEAR CASE / GOVERNOR

GEAR CASE ASSEMBLY

1. Remove the drive belt and the crankshaft pulley.
2. Remove the alternator.
3. Remove the water pump assembly.

WATER PUMP ASSEMBLY

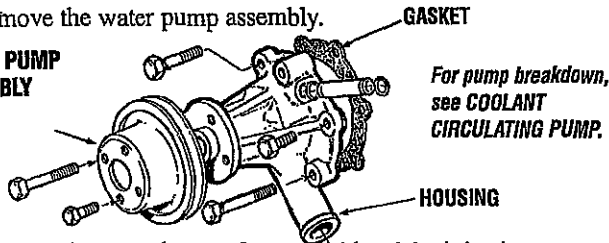

4. Remove the tie-rod cover from the side of the injection pump.
5. Being careful not to let the spring fall into the case, remove the tie-rod and the tie-rod spring.
6. Remove the governor case cover.
7. Remove the gear case assembly.
8. Inspect the disassembled parts. Replace parts worn beyond standard and service limits.

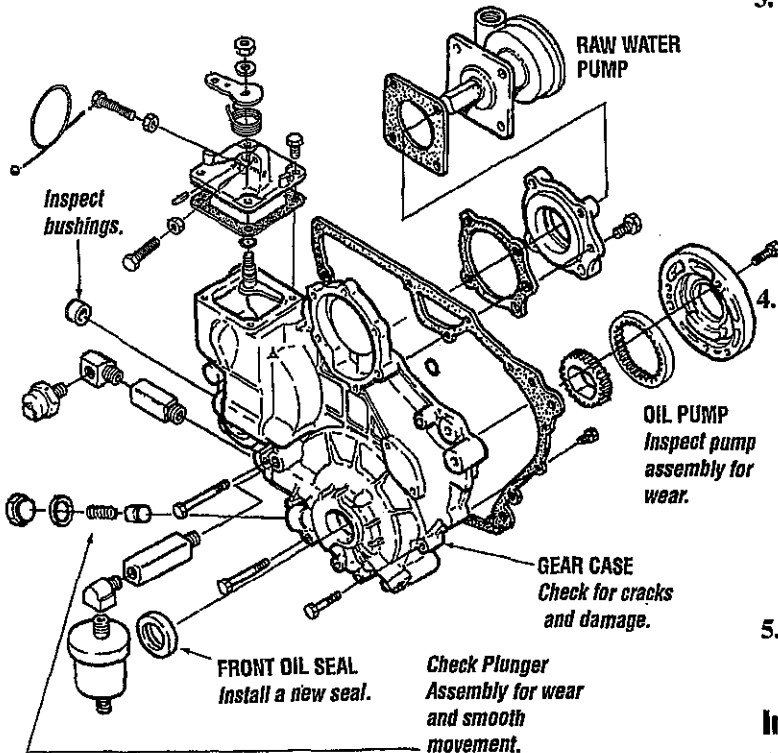

Front Oil Seal Replacement

Remove and replace the front oil seal. Apply a thin coat of engine oil to the circumference and the lip of the new seal before press-fitting it to the gear case cover.

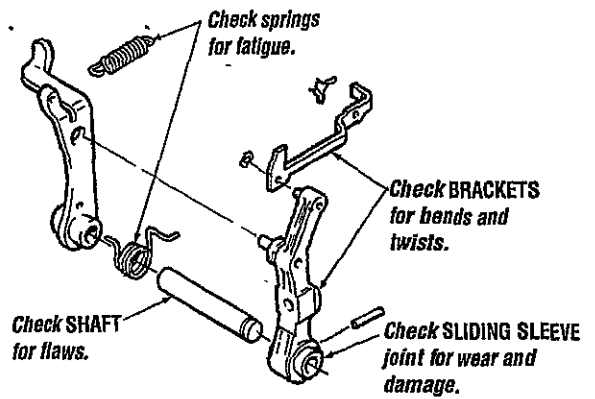

Governor Shaft Disassembly/Inspection

NOTE: For additional information refer to the **GOVERNOR SYSTEM** section.

1. Taking care to not scratch the gear case, remove the expansion plug.
2. Remove the grooved pin.
3. Draw out the shaft and the two bushings.

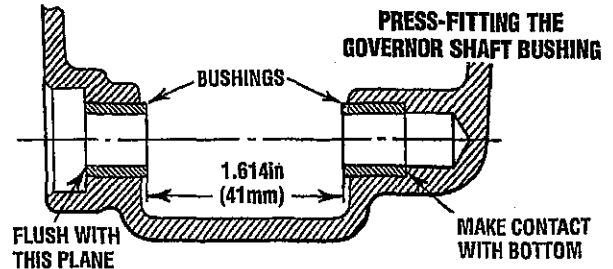

4. Press-fit two new bushings into place as illustrated.

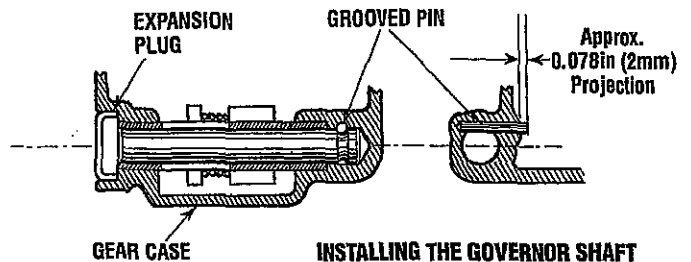

5. Check the governor parts for wear, damage, and fatigue. If any parts are defective, repair or replace them.

Installing the Governor Shaft

Install the governor shaft in the reverse order of removal then press-fit the expansion plug into the shaft hole in the gear case.

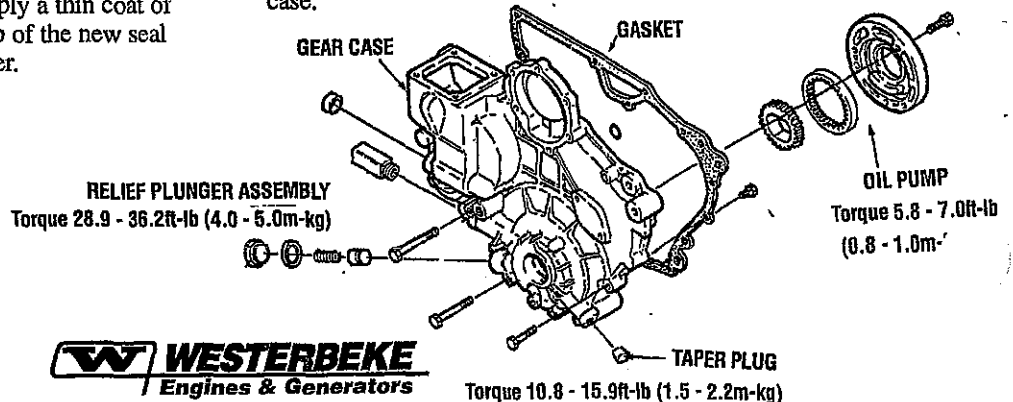

TIMING GEAR / CAMSHAFT

REMOVING THE TIMING GEARS

1. Remove the snap ring and disassemble the idler gear.
2. Remove the valve camshaft and the injection pump camshaft on which the gears are press-fitted, remove the gears.
3. Remove the crankshaft. Remove the crankshaft gear.

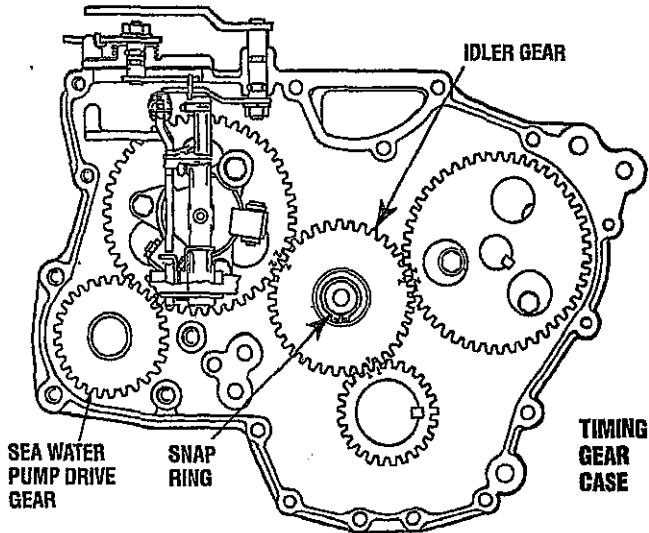

Installation

Press-fit the crankshaft gear onto the crankshaft.

Press-fit the valve camshaft gear and the injection pump camshaft gear onto their respective shafts.

Install the gear assemblies in the following sequence.

1. Turn the crankshaft to set the #1 cylinder to T.D.C. On the compression stroke.
2. Install the valve camshaft and injection pump camshaft.
3. Install the idler gear so that the timing marks on it are aligned with the marks on the other gears.
4. Check that the timing gears are all in alignment.

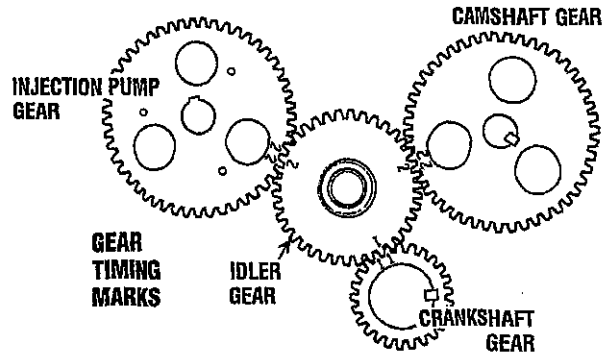

VALVE CAMSHAFT REMOVAL

If only the camshaft is being removed, use the following procedure:

1. Dismount the cylinder head assembly.
2. Pull out the push rods.
3. Pull out the tappets.
4. Remove the gear case assembly.
5. Remove the camshaft stopper bolt.
6. Draw out the camshaft assembly.

INJECTION PUMP CAMSHAFT REMOVAL

1. Disconnect the injection pumps.
2. Remove the injection pump assembly.
3. Remove the gear case.
4. Remove the shaft rear cover.
5. Pull the shaft out to the front side.

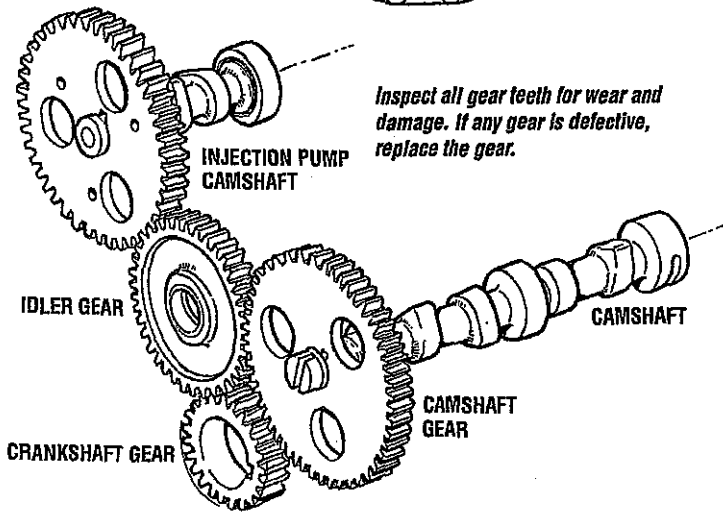

Timing Gear Inspection

Carefully inspect the gears, gear teeth and gear bushings. Check the clearance between the idler gear bushing and its shaft.

Idler Gear Bushing Clearance

Standard	0.03 - 0.07mm (0.001 - 0.010in)
Limit	0.2mm (0.008in)

When assembled, check the backlash between the two gears in mesh. Idler gear to crankshaft, injection pump to idler, and camshaft to idler.

Backlash Between Gears

Standard	0.01 - 0.14mm (0.0003 - 0.005in)
Limit	0.3mm (0.012in)

Replace any gear that fails to meet the above specifications.

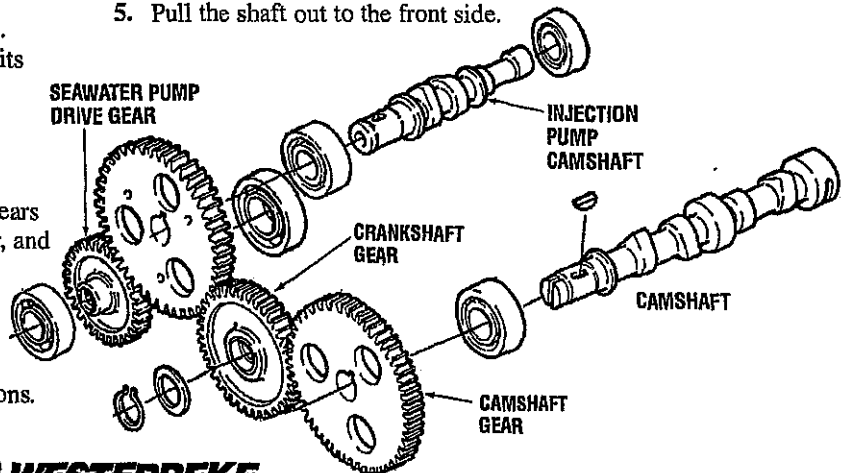

CAMSHAFT / PISTONS AND CONNECTING RODS

Inspecting The Camshaft

Make a thorough inspection of the injection pump and the valve camshafts. Check the Oldham's coupling, each ball bearing and the cam lobes for wear. Also check the push rods and tappets.

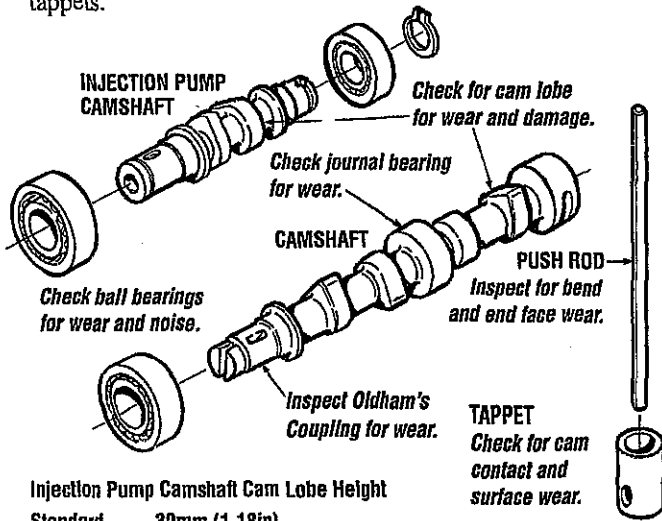

Injection Pump Camshaft Cam Lobe Height
Standard 30mm (1.18in)
Limit 0.7mm (0.027in)

Valve Camshaft Lobe Height
Standard 27.37mm (1.078in)
Limit 1.0mm (0.039in)

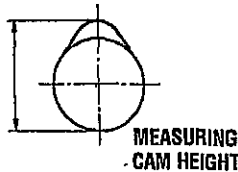

Installing The Camshafts/Gears

Coat the cam lobes and bearings with oil then install them in the reverse order of removal.

Position the timing marks on the gears aligning them with the marks on the idler gear. After installation is complete check and adjust the fuel injection timing and valve clearances.

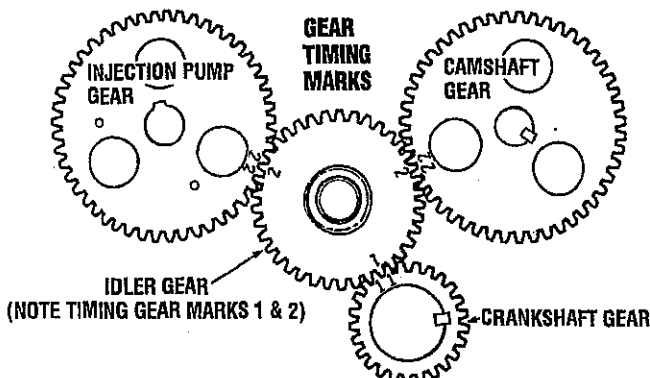

PISTON AND CONNECTING ROD DISASSEMBLY

Remove the oil pan, gasket and the oil screen strainer. Chalk the cylinder number on the side face of the big end of each connecting rod to prevent confusing the connecting rods. Remove the connecting rod cap from each piston and rod assembly and draw the assembly upward from the cylinder. Take care not to allow the connecting rod to scratch the crankshaft pin and cylinder. Keep the removed parts (connecting rod, rod cap, piston, etc.) classified by cylinders.

Remove the rings from each piston with the piston ring pliers. Using the piston setting tool, pull out the piston pin from each piston.

Protecting your eyes with safety glasses, disengage and withdraw the snap rings. Although mechanics generally press out (and sometimes hammer out) piston pins, these practices are discouraged. Instead, time should be taken to heat the pistons, either with a heat gun or by using a hot plate. Pins will almost fall out of heated pistons.

While the piston is still warm, check for bore integrity. Insert the pin from each side. If the pin binds at the center, the bore might be tapered; if the bore is misaligned, the pin will click or bind as it enters the far boss.

NOTE: The number stamped on the rod shank and cap should correspond to the cylinder number. Sometimes these numbers are scrambled or missing, and the mechanic must supply them. Stamp the correct numbers on the pads provided and, to prevent confusion, deface the originals.

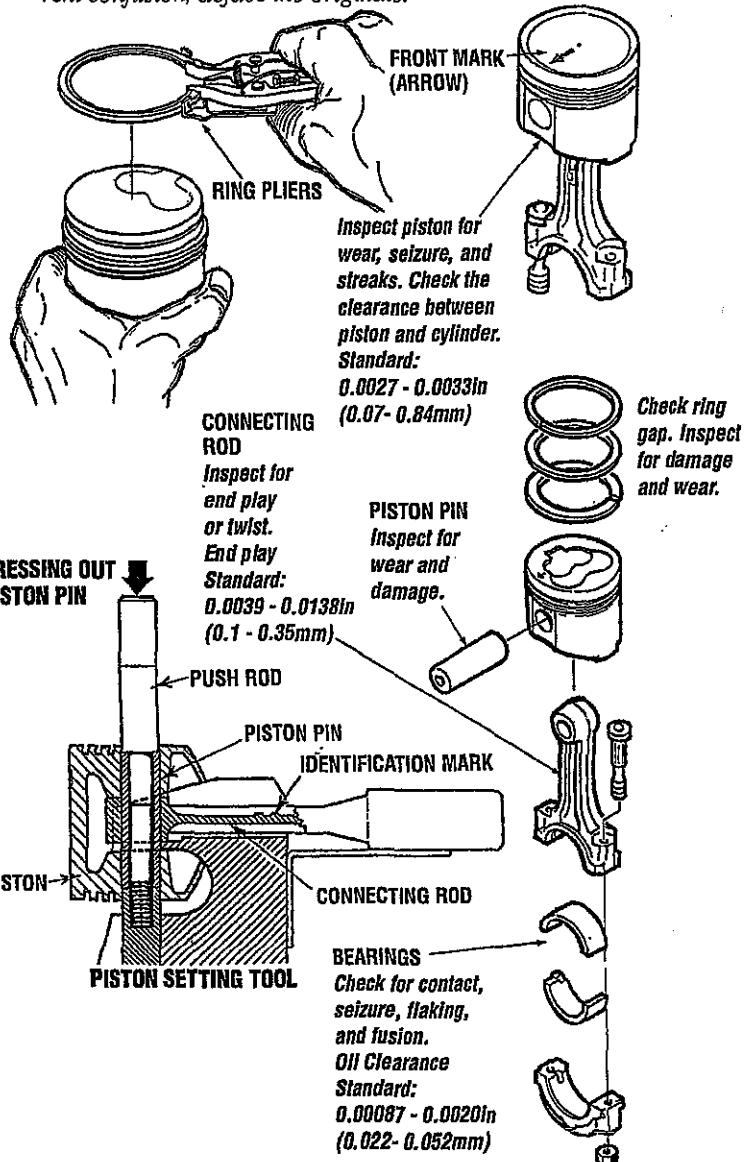

PISTON AND CONNECTING ROD

INSPECTION

Inspect the parts as indicated in the illustration.

Damage, wear and ring gap.

Wear, seizure and streaks.
Clearance between piston and cylinder standard:
0.003 - 0.005 in (0.07 - 0.084mm)

Wear of piston ring grooves

Damage and wear.

Bend and twist.
Big end play standard:
0.0039 - 0.0138 in (0.1 - 0.35 mm)

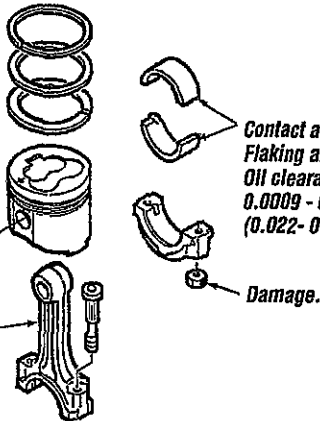

Piston Ring End Gap

Put each piston ring into the cylinder bore and push the ring with the piston to position the ring on square with the cylinder wall. Measure the ring gap with a feeler gauge. If the measurement exceeds the service limit, replace that piston ring.

When only the replacement of rings is to be made, without reboring (honing) of the cylinder, position the ring to be measured at the least worn place of the cylinder skirt. Install the new rings having the same size as the piston. Piston rings available for servicing are sized into three classes: STD, 0.25 OS, and 0.50 OS.

Measuring Ring Gap

Standard (All Rings) 0.006 - 0.016in (0.15 - 0.40mm)
Limit (All Rings) 0.059in (1.5mm)

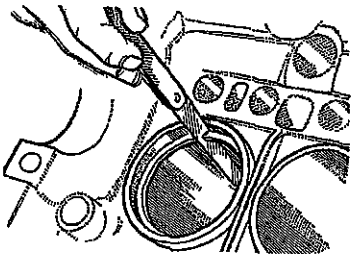

Piston Ring Side Clearance

Measure the side clearance for each piston ring set in the ring groove in the piston. If the service limit is exceeded, replace the ring with a new one.

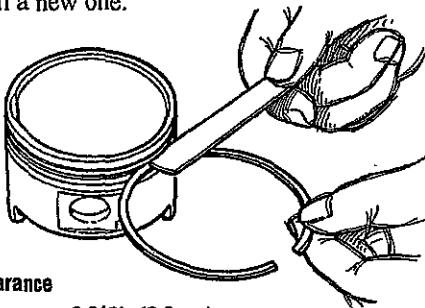

Ring Side Clearance

No. 1	Limit	0.012in (0.3mm)
No. 2	Standard	0.002 - 0.004in (0.05 - 0.09mm)
	Limit	0.007in (0.2mm)
Oil	Standard	0.001 - 0.002in (0.03 - 0.07mm)

NOTE: No. 1 Ring is of the semi-keystone type.

INSTALLATION

1. Reassemble the piston and connecting rod, using the Piston Pin Setting Tool, by pressing the piston pin in to the set position.

Pin Press-fitting Force

Standard 2204.6±110.2lb (1000 ±500kg) (at normal temperature)

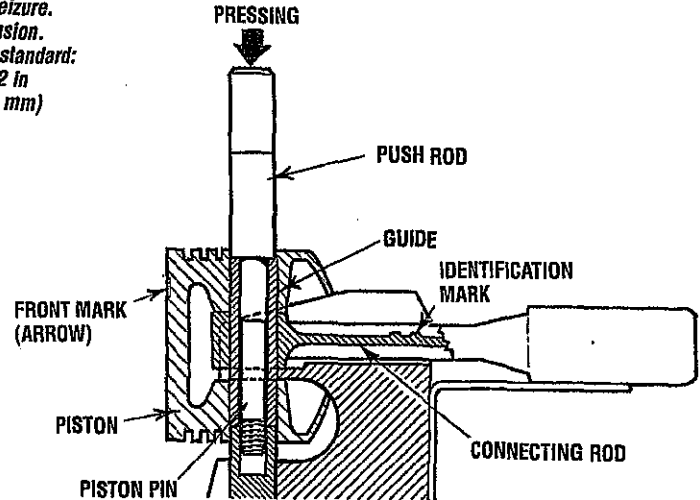

Ring Set positions:
No. 1 Ring,
No. 2 Ring,
oil ring.

FRONT MARK

ROD FRONT MARK

Align notches accurately with each other.

TIGHTENING TORQUE:
23.0 - 25.3ft-lb
(3.2 - 3.5m-kg)

"T" mark and OS size mark.

"T" mark and OS size mark.

OS size identification paint.

STD = without color
0.25 = White
0.50 = Blue

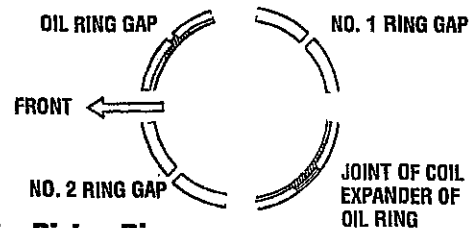

Install The Piston Rings

Set the piston ring gaps to the proper position as shown in the illustration. Coat the rings and cylinder wall with oil.

PISTON AND CONNECTING ROD

Place a heavy hammer as shown. Gently press down with the force of your hand. The entire surface should be coated with fresh lube oil.

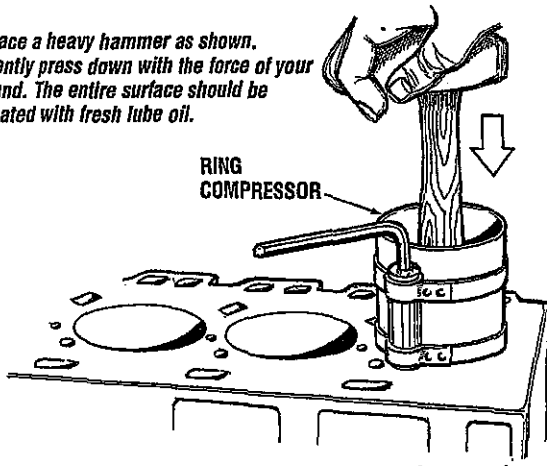

Coat the bearing surface of the connecting rod caps with engine oil. Fit each cap to the connecting rod using the match marks that were put on the before disassembly. In the event a new rod does not have a mark, position the notches (provided for preventing the bearing from rotating) on the same side.

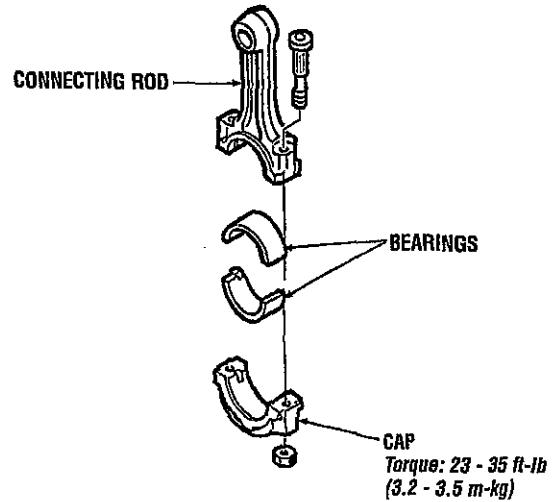

Install The Piston And Connecting Rod Assembly

Using a piston ring compressor to compress the rings into the grooves, push the piston and rod assembly down into the cylinder. Be careful not to break the rings by excessively knocking the head of the piston. Note that the front marks on the piston and the connecting rod are toward the front of the engine.

CRANKSHAFT

REMOVAL AND INSPECTION OF THE CRANKSHAFT ASSEMBLY

1. Loosen the flywheel bolts and remove the flywheel.
2. Loosen the crankshaft pulley nut and remove the pulley.
3. Remove the oil seal assembly.
4. Remove the main bearing caps.
5. Remove the crankshaft.
6. Inspect all disassembled parts and repair or replace any parts that warrant it. Refer to the illustration callouts for inspection procedures.

CRANKSHAFT

Inspect the journals and pins for damage and uneven wear. Check for cracks, clogging of oil holes and bend.

Check wear of journal contact surfaces.

Inspect for damage to the end face of the Crankshaft Gear.

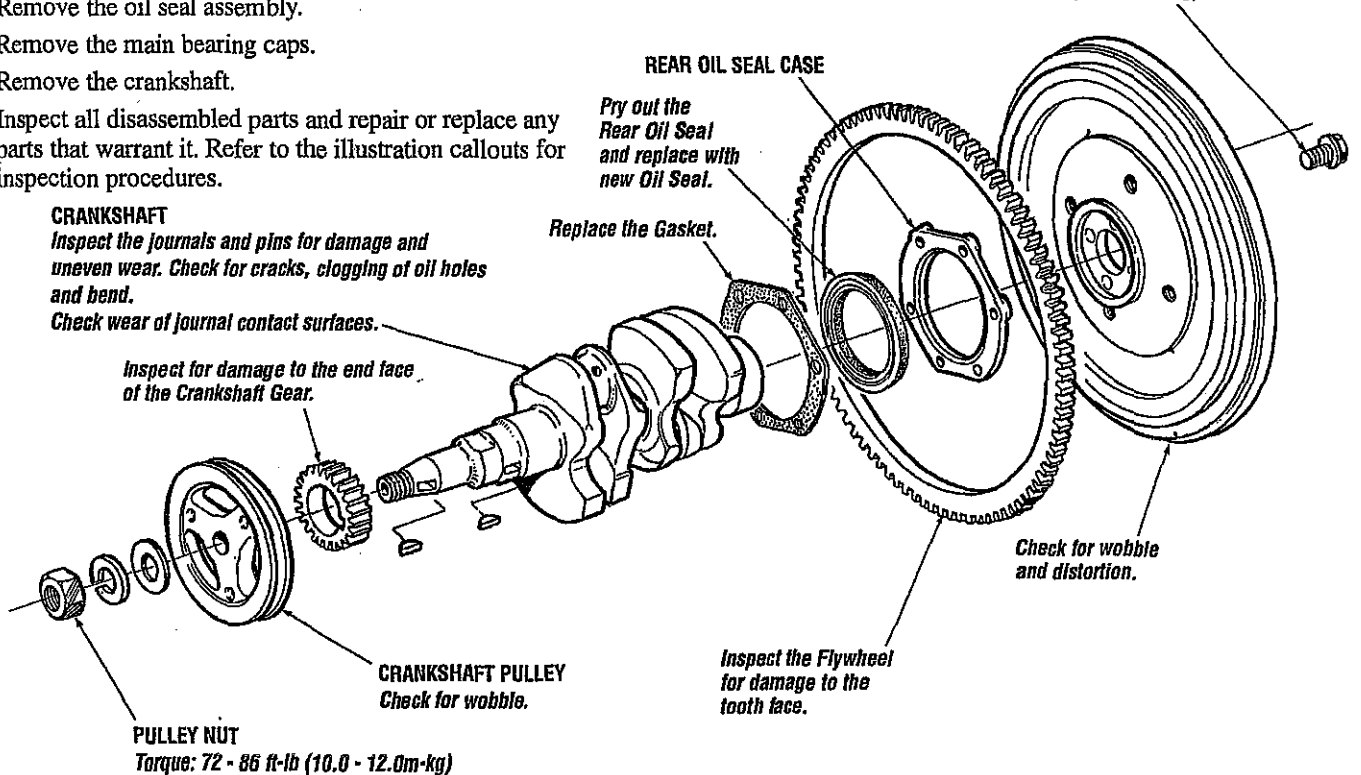

Rear Oil Seal Replacement

Pry out the oil seal with a screwdriver and press a new rear seal into the oil seal case.

CRANKSHAFT

INSPECTING THE CRANKSHAFT

To check the crankpins and main journals for tapering and out-of-round wear, the diameter of each crankpin or main journal should be measured at two places along the crankpin or main journal, in two directions "A" and "B" each place. If necessary, regrind the crankpins and main journals to the next undersize. If any crankpin or main journal has been worn beyond the service limit, replace the crankshaft.

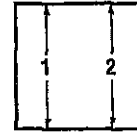
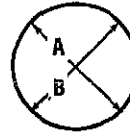

MEASURING MAIN BEARING I.D.

NOTE: A crankshaft which has been sized cannot be reground to any undersize.

Main Journal Diameter

Standard 1.693in (43mm)
Limit -0.0275in (-0.70mm)

Crankpin Diameter

Standard 1.575in (40mm)
Limit -0.0275in (-0.70mm)

Main Journal Undersize Diameter

0.25 US 30.885 - 30.896in (42.715 - 42.730mm)
.50 US 30.704 - 30.715in (42.465 - 42.480mm)

Crankpin Undersize Diameter

0.25 US 28.715 - 28.727in (39.715 - 39.730mm)
0.50 US 28.535 - 28.546in (39.465 - 39.480mm)

Oil Clearance Service Limit

Main Bearing 0.004in (0.10mm)
Rod Bearing 0.006in (0.15mm)

Tightening Torque

Main Bearing 36 - 38 ft-lb (5.0 - 5.5m-k)
Rod Bearing Cap Nut 23 - 35 ft-lb (3.2 - 3.5m-k)

Crankshaft End Play 0.002 - 0.007in (0.05 - 0.175mm)

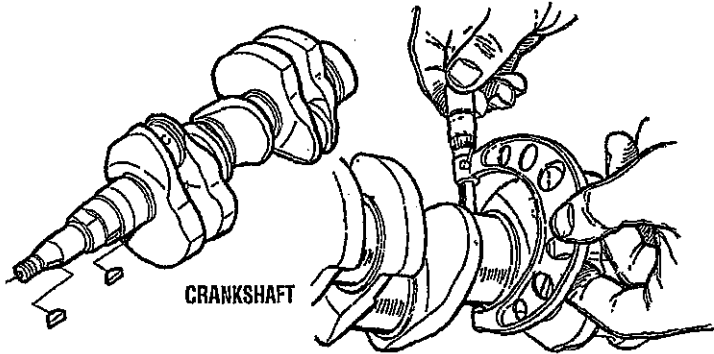

INSPECTING THE CRANKSHAFT OIL CLEARANCE

Oil clearance is calculated by subtracting the diameter of the main journal or crankpin from the inside diameter of the main bearing or rod bearing. To check the main bearings and rod bearings for tapering wear and out-of-round wear, the inside diameter of each main bearing or rod bearing should be measured. After its bearing cap is fastened at the specified torque, measure the bearing at two places along the length of the bearing and in the directions "A" and "B" each place as shown. If necessary, replace the worn bearing with a new one. If the oil clearance still exceeds the service limit, regrind the crankshaft to the next undersize and replace the bearing with one of the corresponding undersize.

INSTALLING THE CRANKSHAFT

Refer to the callouts in the illustration below.

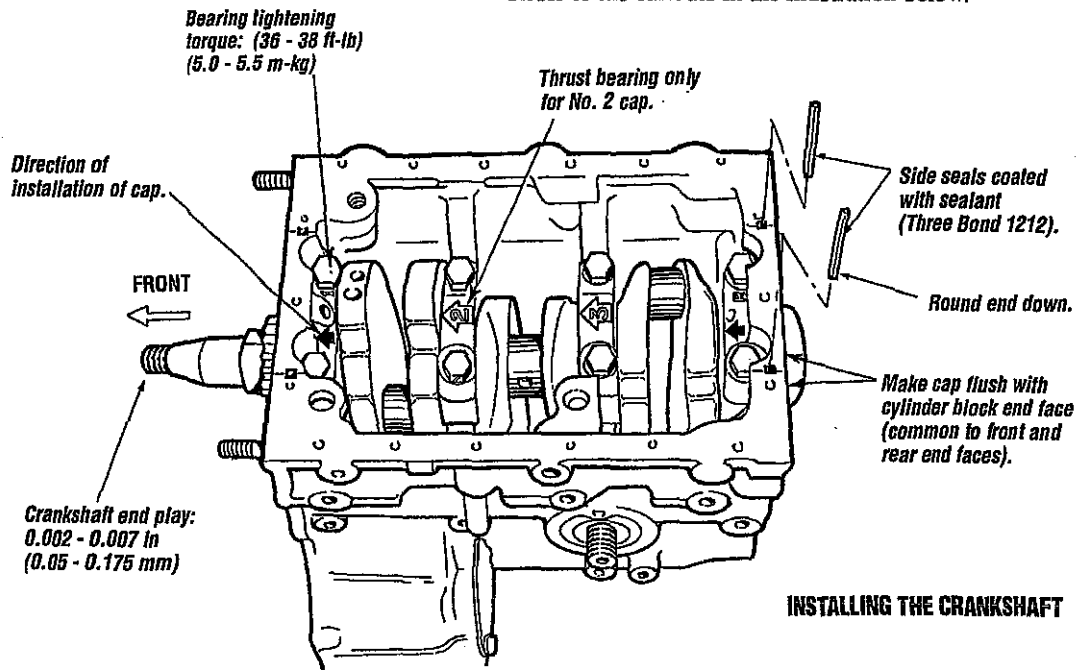

INSTALLING THE CRANKSHAFT

CYLINDER BLOCK

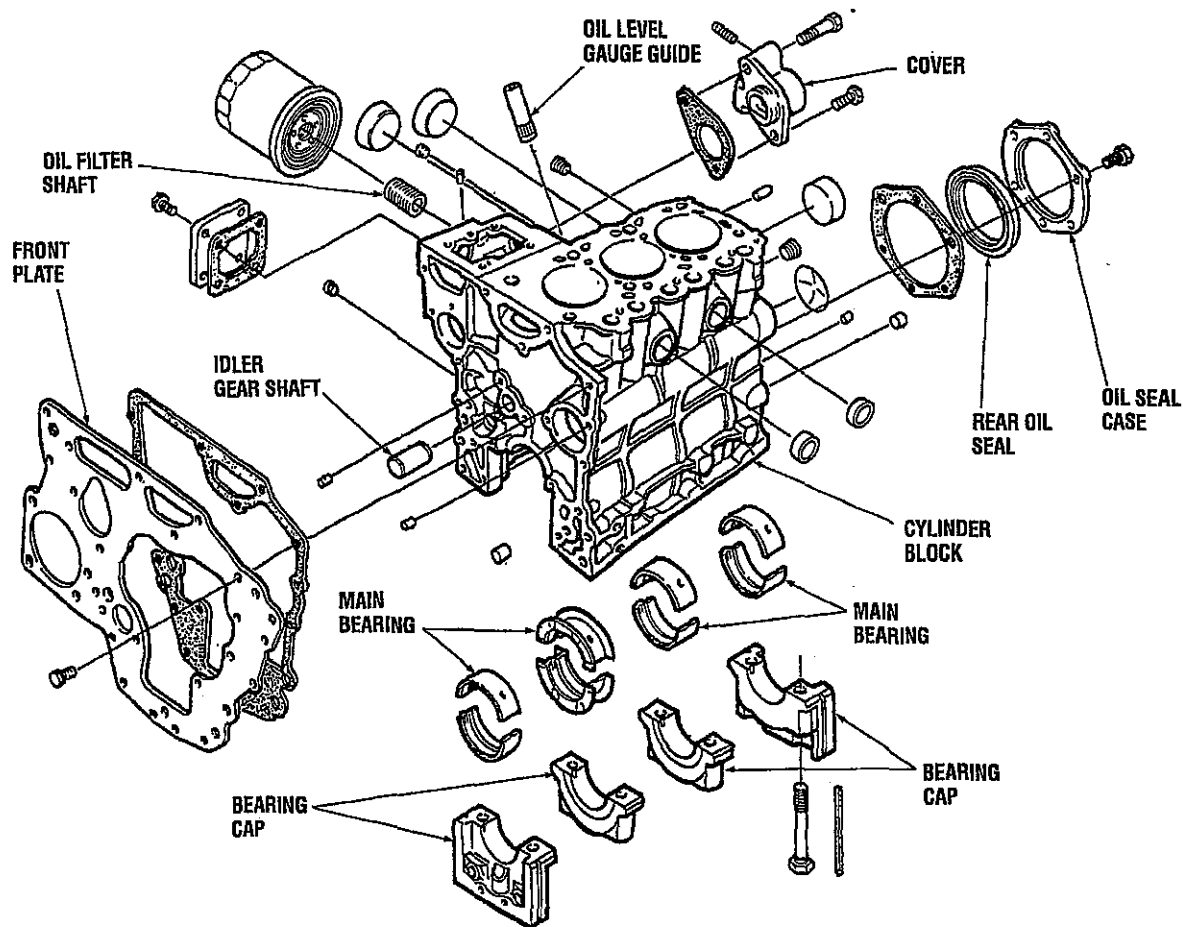

CYLINDER BLOCK INSPECTION

Check the cylinder block for cracks and damage. If necessary, repair or replace it entirely. Check to see that oil or cooling water passages are not clogged and, if clogged, remove with compressed air or a wire.

Cylinder Bore Dimensions

	5.0KW Generator	7.6KW Generator
Standard	2.559in (65 ± 0.03mm)	2.992in (76 ± 0.03mm)
Wear Limit for Rebore	0.008in (0.2mm)	0.008in (0.2mm)

NOTE: When it is necessary for a cylinder to be rebored to the next oversize, the remaining cylinders must also be rebored to the same oversize.

Cylinder Reboring

Use the following procedure when reboring a cylinder:

- Select a piston size:
0.25mm Over Size (OS) or 0.50mm OS
- Measure the piston diameter.
Reboring finish dimension =
(Piston OD) + (Clearance) - (Honing Allowance [0.2mm])

Clearance between piston and cylinder
0.0027 - 0.0033in (0.071 - 0.084mm) (A-D)

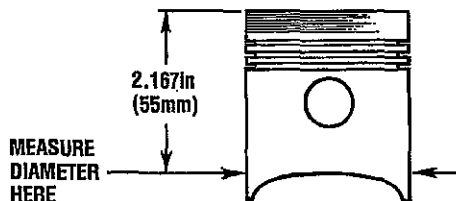

MEASURING PISTON DIAMETER

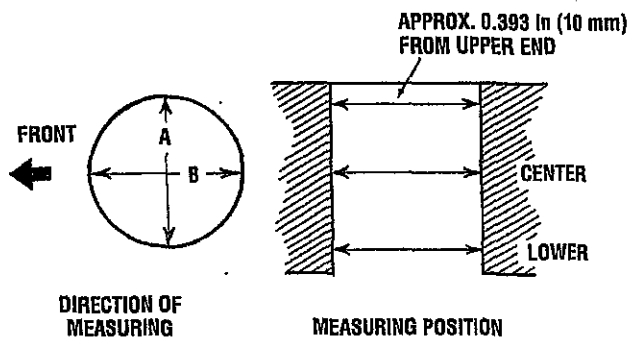

CYLINDER BORE MEASURING POSITIONS

GOVERNOR SYSTEM

INSPECTING THE GOVERNOR COMPONENTS

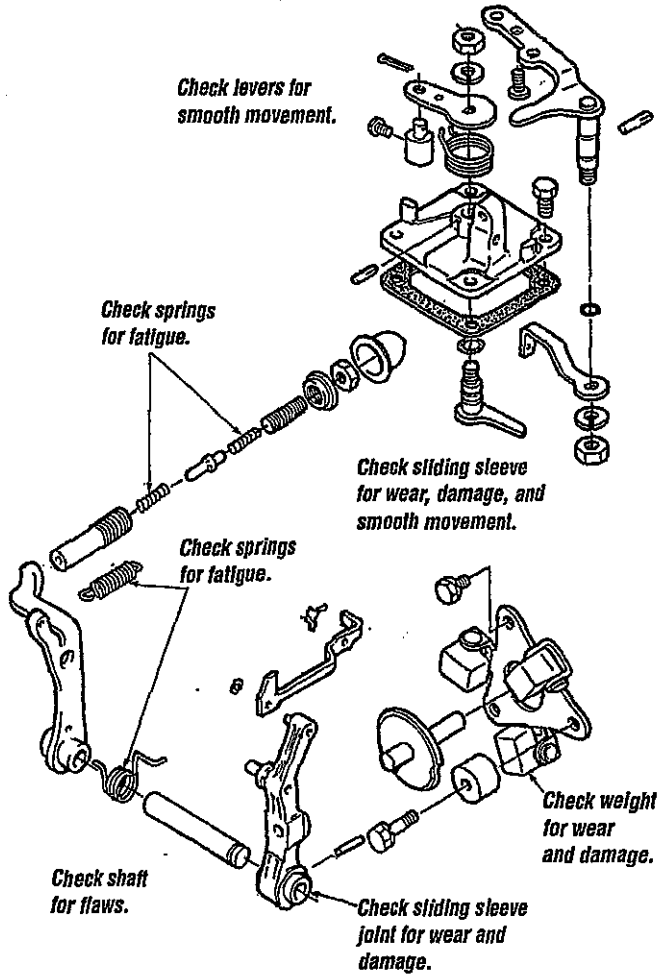

Disassembly and Inspection

With the gear case removed, disassemble the governor system. When removing the gear case, be sure to remove the tie-rod cover by the side of the fuel pump and disconnect the tie-rod from the rack. Replace all parts that warrant replacement.

Governor Removal

To remove the levers, pull out the grooved pins which have been driven into the governor lever and speed control lever. Loosen the bolts that fasten the levers and shafts.

NOTE: When inspecting a malfunctioning governor also check the bearing on the gear case side.

Inspect and reassemble the levers and shafts, checking them for proper operation.

After press-fitting each grooved pin, check the shaft for smooth operation and rotation. Coat the o-rings with oil before installing them. Deflection must not exceed 0.787in (20mm) with the governor spring installed.

Install the governor spring lever and the speed control lever so that the play angle between the levers (5°) is minimized.

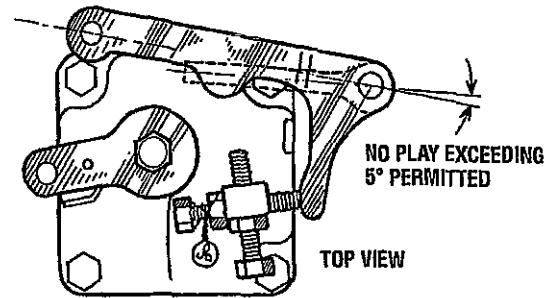

INSTALLING THE SPEED CONTROL LEVER

TORQUE SPRING SET ASSEMBLY

When the torque spring set has been disassembled and inspected and defective parts replaced, reassemble and adjust the torque spring set using the following procedure:

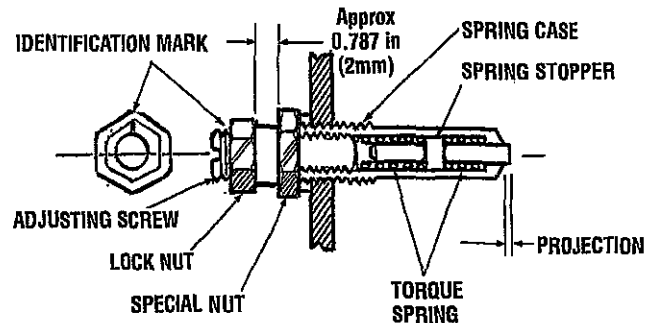

TORQUE SPRING SET

Assemble the Torque Spring Set

Use the adjusting screw to set the projection of the torque spring stopper from the spring case to get the specified projection.

To measure the projection keep the torque spring set in the vertical position as illustrated.

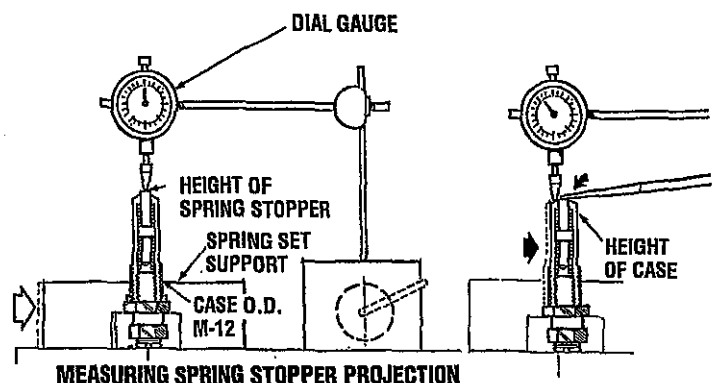

Then put the dial gauge probe against the spring stopper at the center of its end face using a dial gauge with a sensitive probe which does not compress the torque spring when pushed against the spring stopper end.

GOVERNOR

Leaving the dial gauge set, its condition unvaried, depress the spring stopper and slide over the torque spring set support spring case. Read the deflection of the dial gauge which corresponds to the projection of the spring stopper from the spring case (Measurement should be made repeatedly for an accurate measure). For the models which do not require any torque spring action, set the projection to a value in the range of 0 to -0.4.

After making the adjustment tighten the locknut to a torque of 5.8 - 9 ft-lb (0.8 - 1.2kg-m).

ELECTRONIC GOVERNOR ACTUATOR

The electronic governor actuator regulates engine speed by allowing more or less fuel to be delivered to the injectors to maintain a constant flywheel speed signal (AC) from the MPU (magnetic pick-up unit) to the ECU (electronic control unit). The ECU interprets this AC signal as speed and sends a varying DC voltage to the actuator for it to work with it depending on the amperage load.

NOTE: When the STOP is energized and the unit only drops to idle and does not stop, the actuator is not positioned correctly. Loosen the jam nut and thread the actuator slowly in until the unit shuts down completely.

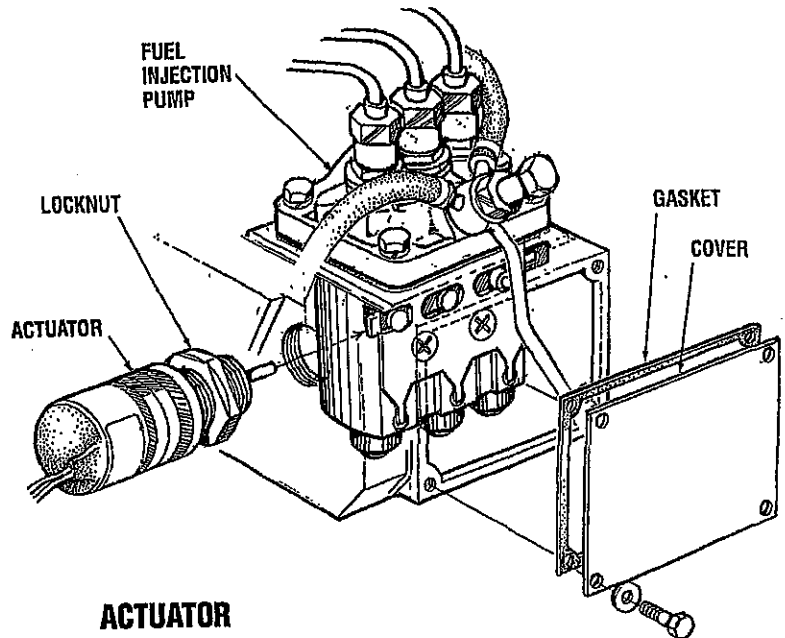
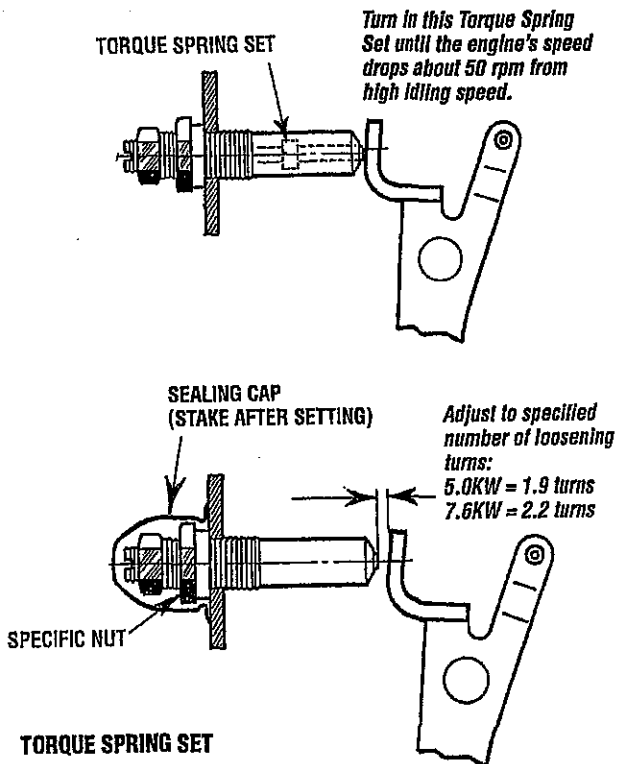

ACTUATOR

The following instructions are for adjusting or replacing the actuator:

1. Shut-off the DC power to the generator.
2. Disconnect the actuator wires from the wiring harness.
3. Measure the distance between the actuator and the engine mounting surface as shown.
4. Back-off the 1 7/16" jam nut and unscrew the actuator.
5. Apply a small amount of teflon sealant to the replacement actuator and screw the actuator into the engine's mounting boss. Maintain the same distance between the actuator and the engine mounting surface as previously measured. Secure the actuator's position with the jam nut. (The standard distance is 13/16" to 7/8")
6. Reconnect the actuator wires and test the unit.

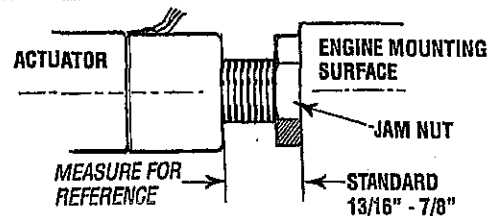

TORQUE SPRING SET INSTALLATION

NOTE: This adjustment is done at engine overhaul with no generator installed or with the leads removed from the generator capacitor.

Use the following procedure to install and adjust the Torque Spring Set.

1. Set the speed control to the high idling speed (3600 rpm) position by adjusting the high speed set bolt.
2. Turn in the torque spring set until the engine speed drops about 50 rpm from the high idle speed.
3. From this position, turn back the torque spring set by the specified number of turns (N). Lock the torque spring set at that position with the special nut.
N = 1.9 turns (5.0 KW)
N = 2.2 turns (7.6KW)
4. Install the torque spring set sealing cap and stake the cap to prevent further loosening.

ENGINE ASSEMBLY

Install the Thermostat and Thermostat Housing

1. Inspect the thermostat housing and the housing gasket. Apply some sealant to the gasket when reassembling.
2. Install the temperature switch and sender and reconnect their wires.
3. Install a new thermostat and gasket (the old thermostat can become a spare). When installing the new thermostat and gasket, apply a thin coat of sealant to both sides of the gasket.
4. A thermostat can be checked for proper operation by placing it in a pan of cold water and then raising the temperature of the water to a boil. The thermostat should open noticeably (with travel on the order of 1/4 - 1/2in (0.0098 - 0.0197mm) and be fully opened when the water is boiling.

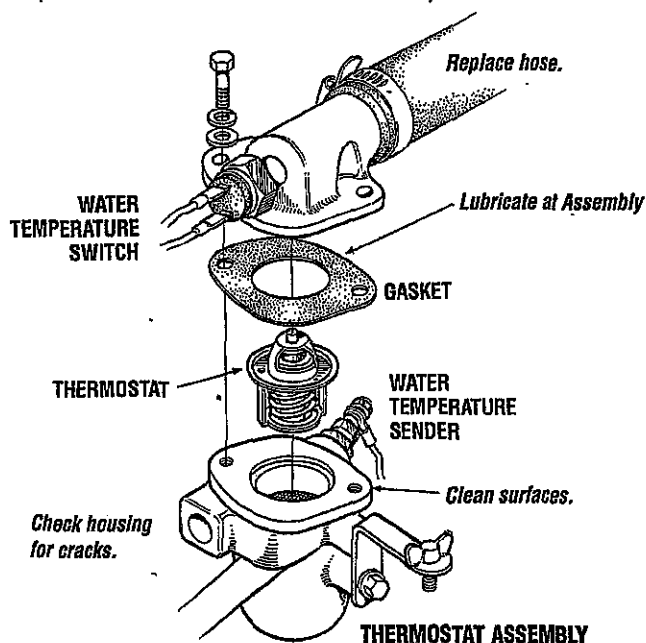

Install the fuel injection nozzles. Install the fuel overflow pipe. Use new sealing washers throughout, in the same order as were the old washers.

Injector Tightening Torque 43 - 51 ft-lb (5.0 - 6.0 m-kg)

See FUEL INJECTORS

Install the glow plugs and connectors. Use anti-seize compound on the threads.

Glow Plug Tightening Torque 7.2 - 10.8 ft-lb (1.0 - 1.5 m-kg)

To test the glow plugs, see GLOW PLUGS

Mount the rocker arm cover and Crankcase vent hose.

Rocker Arm Cover Tightening Torque 1.8 - 2.9 ft-lb (0.25 - 0.40 m-kg)

Connect the fuel line to the engine mounted fuel filter and the line to the injection pump. Use new sealing washers.

Connect the high pressure injector lines from the injection pump to injectors. Reinstall the line clamp.

Attaching Nuts Torque 18 - 22 ft-lb (2.5 - 3.0 m-kg)

Install the bellhousing.

Install the air intake silencer.

Mount the engine heat exchanger and engine oil cooler on the flywheel bellhousing.

The heat exchanger should be serviced at engine overhaul. Refer to EXHAUST MANIFOLD/HEAT EXCHANGER.

Install the coolant pump assembly.

Coolant Pump Assembly Tightening Torque 12 - 17 ft-lb (1.6 - 2.3 m-kg)

See COOLANT CIRCULATING PUMP for coverage of the complete breakdown of the coolant pump assembly.

Adjust the injection timing.

See INJECTION TIMING.

Mount the oil filter bracket and install a new filter. When installing the new filter apply a thin coat of clean engine oil to the rubber gasket. Tighten by hand.

Mount the front engine mounting bracket.

Mounting Bracket Tightening Torque 33 - 49 ft-lb (4.6 - 6.8 m-kg)

Install the intake manifold.

Intake Manifold Tightening Torque 11.6 - 17.4 ft-lb (1.6 - 2.4 m-kg)

Mount the fuel filter assembly.

ENGINE ASSEMBLY

Install the alternator and drive belt.

CAUTION: Connect the alternator properly. Should the polarity be reversed, a powerful current would flow from the battery into the alternator, damaging the diodes and wiring harness.

Install the alternator support bolt through the alternator leg (underside) into the engine casting.

Swing the alternator into position on the adjusting bracket and fasten. Lightly tighten.

Adjust belt tension.

Tighten both bolts and recheck belt tension.

Support bolt Torque Values 15 - 18 ft-lbs (2.1 - 2.52 m-kg)
Adjusting bracket bolt Torque Values 9 - 10 ft-lbs (1.26 - 1.4 m-kg)

NOTE: Make certain the belts are perfectly aligned with the alternator and engine pulleys. If not, insert or remove spacers as needed, to align the alternator.

See ALTERNATOR for service and testing.

Install the raw water pump and drive belt. Insure it is in proper alignment with the crankshaft pulley. Check tension. Refer to RAW WATER PUMP.

Install the oil and water sensors and switch.

Install the starter motor.

Install the breaker panel and the preheat solenoid.

Reinstall the engine electrical harness.

Mount the complete exhaust manifold and the expansion tank to the cylinder head.

Manifold Mounting Bolts Torque Values 20 - 24 ft-lb (2.7 - 3.3 m-kg)

See EXHAUST MANIFOLD/HEAT EXCHANGER for service and inspection.

Install new hose connections and clamps for the cooling system.

CAUTION: Check all AC and DC wiring connections to WESTERBEKE's wiring schematics and diagrams.

Generator. Mount the generator back end assembly with it's control panel. Reconnect all DC wiring and reconnect all AC connections.

Fill the engine cooling system with antifreeze mixture and the engine oil sump with lube oil (A.P.I. spec. CF or CG-4).

The generator should be test run under load prior to reinstalling. At this time readjust the valve clearances on the hot engine.

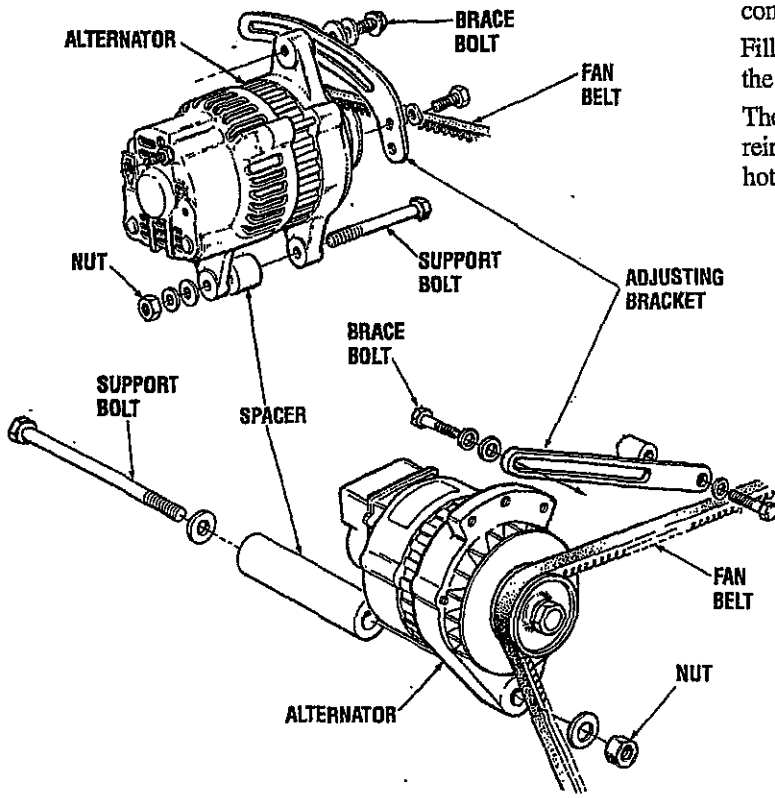

TYPICAL ALTERNATOR ASSEMBLIES

EXHAUST MANIFOLD / HEAT EXCHANGER

EXHAUST MANIFOLD

The exhaust manifold, which was disassembled from the cylinder head, should be inspected before reassembly.

1. Remove the exhaust elbows from the lower surface of the manifold. Clean and inspect for cracks and defects. Replace as needed.
2. Remove the exhaust nipples, elbows and plugs from the manifold.
3. Remove water connectors from the ends of the manifold. Be sure to note the proper location and arrangement of each for proper alignment.
4. Examine all parts for defects, corrosion and wear and replace as needed.
5. Flush out the manifold's interior with a liquid cleaner and rinse thoroughly with fresh water.
6. Use a pipe cleaner to clear the passage that connects the coolant recovery tank tubing.
7. Flush out the coolant recovery tank and its connecting tube.

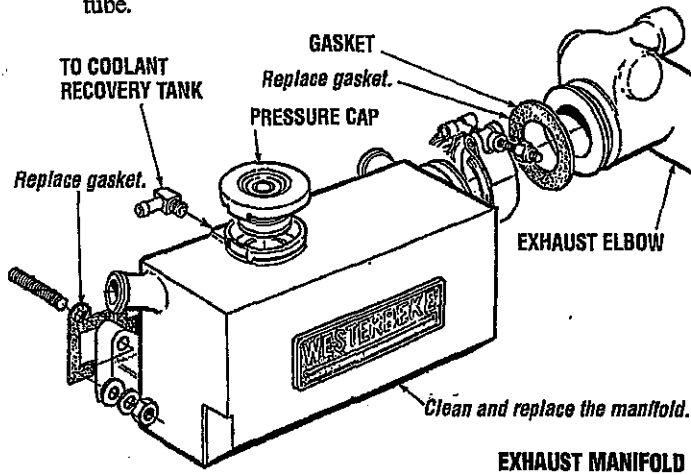

ASSEMBLY

1. If the manifold was removed as an assembly and left intact, it can be replaced on the cylinder head in the reverse order of removal. Do not reuse the gaskets; install new ones.

Manifold Mounting

Bolts Torque Values 20 - 24 ft-lb (2.7 - 3.3 m-kg)

2. If the manifold has been disassembled, follow the steps below.
 - a. Loosely attach the elbows to the cylinder head and the manifold using new gaskets. Do not use any gasket sealant.
 - b. Gradually tighten each fitting to make sure of proper alignment of all the parts. This should be done in three steps.

Manifold Mounting

Bolts Torque Values 20 - 24 ft-lb (2.7 - 3.3 m-kg)

- c. Reinstall the exhaust connections and plugs into the manifold using Loctite-Anti-Seize on the threads.

Check the manifold pressure cap. Open the valve by pulling it and make sure it closes when released. Make certain the upper and lower seals are in good condition. If any doubt, replace the cap.

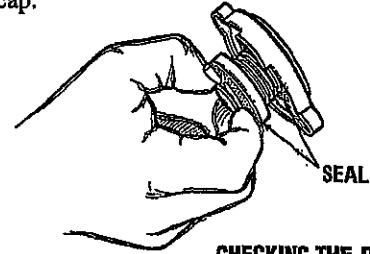

CHECKING THE PRESSURE CAP

HEAT EXCHANGER

The heat exchanger should be inspected and serviced during an engine overhaul.

1. Disconnect the hoses and remove the hose fittings, petcock, drain plugs and zinc anode. Also, remove the end fittings and gaskets.
2. Inspect the tube (casing) for wear and dents, if at all suspect replace the heat exchanger.
3. Clean out any zinc debris and pressure test the coolant and raw water passages.
4. When reassembling, install new gaskets and O-rings. Apply some lubricant to the new gaskets and to the petcocks and fittings as you install them.
5. Install a new zinc anode.

NOTE: All of the above can be accomplished by sending the heat exchanger to a heat exchanger service shop. They will also service transmission and engine oil coolers.

6. Repaint the assembled heat exchanger with Westerbeke heat resistant spray enamel.

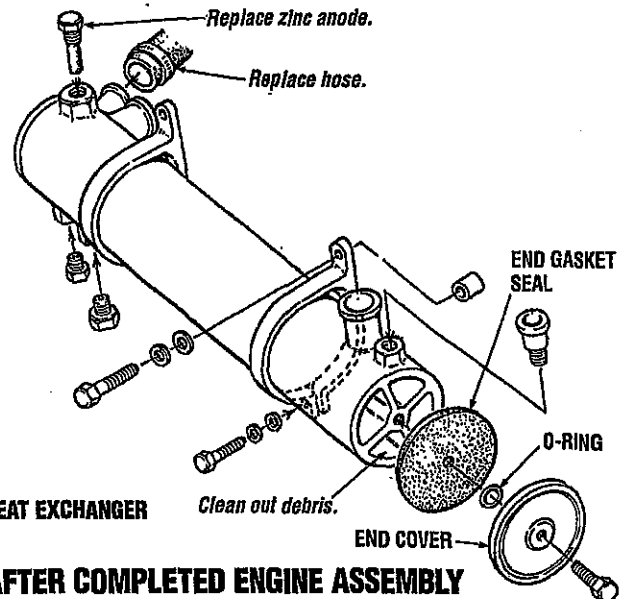

HEAT EXCHANGER

AFTER COMPLETED ENGINE ASSEMBLY

7. Reconnect all hoses, replacing them as needed.
8. Refill the system with coolant as detailed above.
9. Pressure test system and check for leaks.

FUEL INJECTION PUMP

REMOVING THE INJECTION PUMP

NOTE: Do not disassemble the injection pump unless absolutely necessary. Injection pump service should be performed by a qualified technician in an extremely clean environment. If the pump is defective it is recommended the entire pump assembly be replaced.

1. Disconnect the fuel injection pipes.
2. Remove the tie-rod clip cover.
3. Remove the tie-rod clip and the tie-rod.

Disassembly

1. Remove the stopper plate.
2. Unscrew the delivery holder. Take out the delivery valve and valve spring.
3. Remove the tappet roller and stopper pin.
4. Remove the tappet, plunger spring, etc.

NOTE: When replacing the plunger barrel, delivery valve, etc., do not loosen the adjusting screw and plate for each cylinder. When those parts have been replaced, it is necessary to measure fuel injection quantity by utilizing a pump tester and cam box. All parts that are removed from the pump should be kept classified by cylinders and immersed in clean fuel.

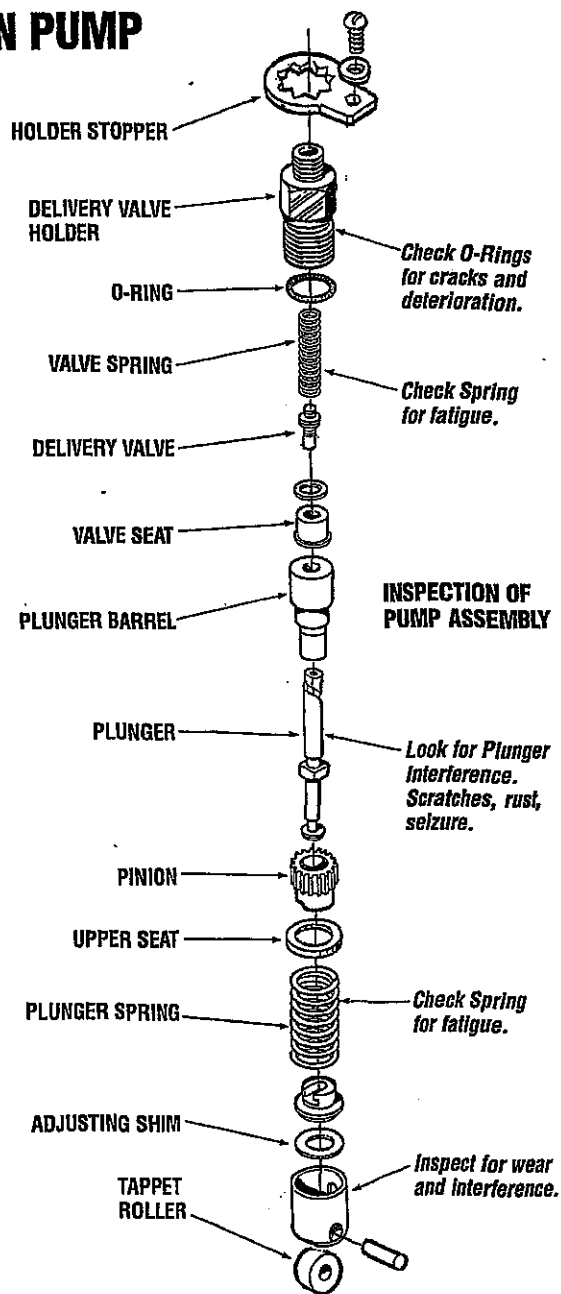
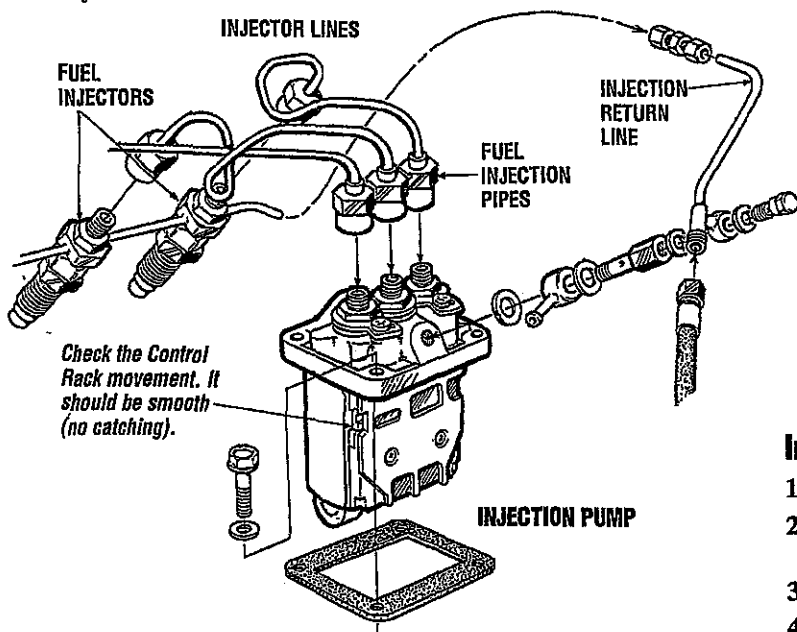

Injection Pump Assembly

1. Insert the plunger barrel into the housing.
2. Install the delivery valve and valve spring. Temporarily tighten the holder.
3. Insert the control rack.
4. Insert the control pinion. Align the matchmark on the rack with that on the pinion.
5. Install the spring upper seat.
6. Insert the plunger spring.
7. Fit the lower seat to the plunger. Insert the plunger into the barrel side.
8. Depress the tappet roller assembly and install the stopper pin.
9. Tighten the delivery holder.

Delivery holder tightening Torque: 25.3 - 28.2 ft-lb (3.5 - 3.9 kg-m).

FUEL INJECTION PUMP / INJECTION TIMING

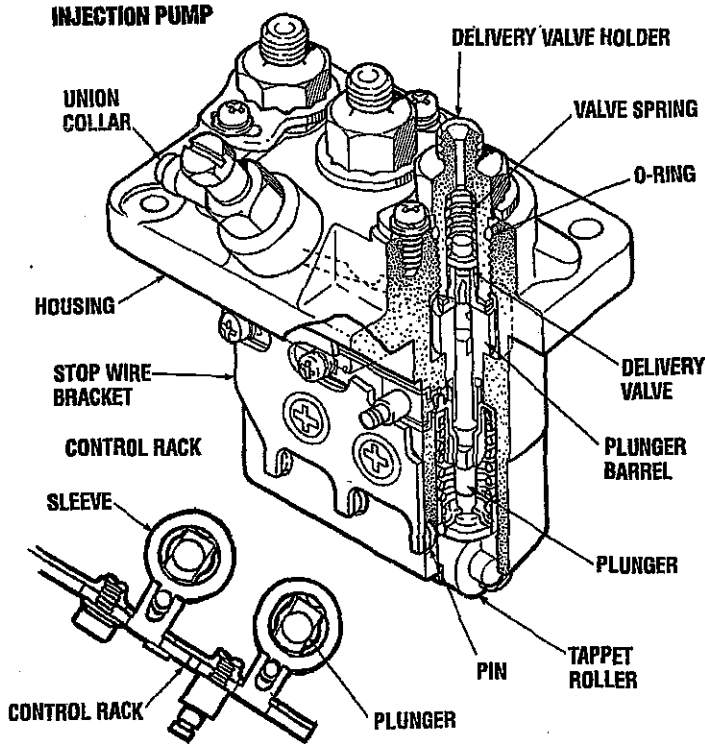

Installing the Injection Pump

Install the injection pump assembly in the reverse order of removal.

NOTE: When installing the plunger barrel, engage the dowel pin on the housing side with the groove in the barrel. Position the plunger so that the part number stamp on its flange faces the direction opposite to the rack side. (Engage the feed hole with the plunger lead.) After installation, check for proper injection timing.

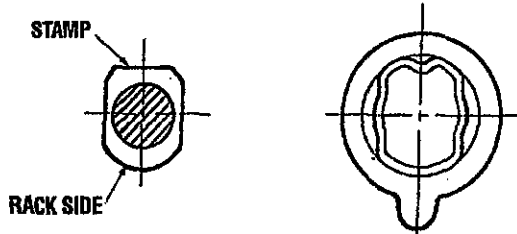

DIRECTION OF PLUNGER

When connecting the injection pipe assembly, loosen the pipe clamp. When tightening the nut at each end of the pipe, grip the nozzle holder or delivery valve holder with a wrench to prevent it from being turned together with the nut. Also, take care not to allow dust to enter the fuel line.

Injection Pump Timing Adjustment (Spill Timing)

This timing adjustment is performed with the engine/generator in operating condition.

If the engine's fuel injection timing is not properly adjusted, the engine will not operate properly and may be difficult to start. Have the injection delivery rate checked by a well-established fuel injection shop. Adjust the injection as follows:

NOTE: The fuel shut-off lever must be in the **RUN** position while making the adjustment or no fuel will flow from the fuel injection pump.

1. Remove the high pressure fuel line from between the No. 1 injector and the No. 1 fuel delivery valve holder.
2. Remove the No. 1 fuel delivery valve holder over o-ring and remove the delivery valve spring beneath the holder.
3. Reinstall only the delivery valve holder and reattach the high pressure fuel line to the delivery holder. Attach it so the end which would connect to the fuel injector is pointing away from the engine. Fuel will flow from this line during the timing check.

Rotate the engine's crankshaft in its normal direction of rotation to position piston No. 1 at the beginning of its compression stroke.

Move the throttle lever to its full open position and operate the electric lift pump. Slowly rotate the crankshaft clockwise (as viewed from the front), catching fuel from the No. 1 fuel line, until the instant the fuel completely stops flowing (no drips). At this instant, the 15° BTDC timing mark on the crankshaft pulley should be directly aligned with the timing indicator on the front of the gear case $\pm .5$ degrees.

If the specified injection timing (15° BTDC) cannot be attained, adjust the timing by increasing or decreasing the thickness of shim material under the injection pump's mounting flange to change the injection timing point. Changing the shim thickness by 0.004 inch (0.01mm) changes the injection timing by approximately one degree. To advance the timing, decrease the shim thickness as required. To retard the timing, increase the shim thickness as required.

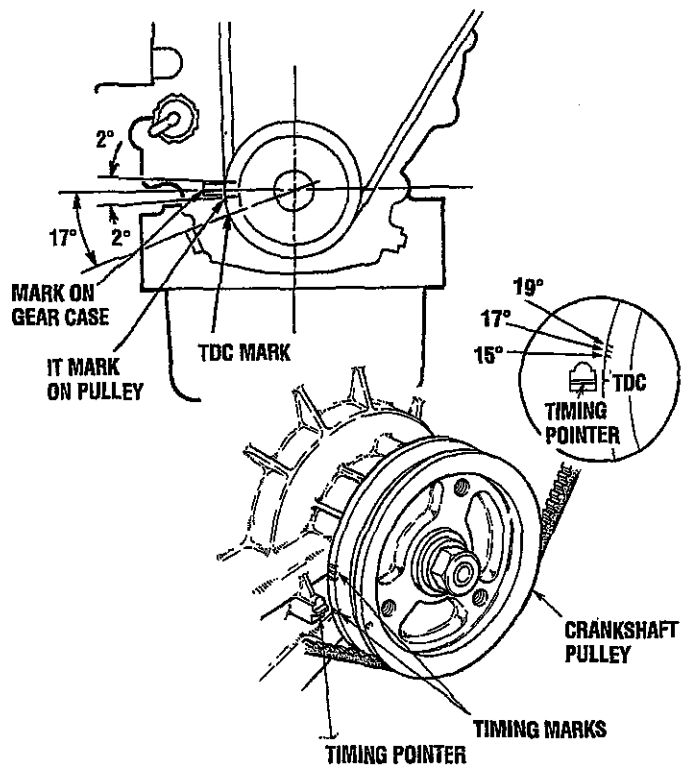

FUEL INJECTORS

REMOVING THE INJECTORS

NOTE: Injector must be serviced in a "clean room" environment.

1. Disconnect the high pressure lines from the injectors and loosen the lines at their attachment to the injection pump and move them out of the way of the injectors. Avoid bending the lines.
2. Using a 17mm long socket, remove the fuel return line in its entirety from the top of the injectors. Take care not to lose the two sealing washers and banjo bolt that attaches the fuel return line to each injector.

NOTE: Clean the area around the base of the injector prior to lifting it out of the cylinder head to help prevent any rust or debris from falling down into the injector hole. If the injector will not lift out easily and is held in by carbon build up or the like, work the injector side to side with the aid of the 17mm deep socket wrench to free it and then lift it out.

3. The injector seats in the cylinder head on a copper sealing washer. This washer should be removed with the injector and replaced with a new washer when the injector is reinstalled.

INJECTION TESTING

1. Using the nozzle tester, check the spray pattern and injection starting pressure of nozzle and, if it exceeds the limit, adjust or replace the nozzle. When using nozzle tester, take the following precautions:

CAUTION: The spray injected from the nozzle is of such velocity that it may penetrate deeply into the skin of fingers and hands, destroying tissue. If it enters the bloodstream, it may cause blood poisoning.

- a. If the diesel fuel of the nozzle tester is discolored, replace it. At the same time, clean or replace the filter.
- b. Set the nozzle tester in a clean place where there is no dust or dirt.
- c. Mount the nozzle and nozzle holder on the nozzle tester.
- d. Use the fuel at the approximate temperature of 68° F (20° C)
- e. Operate the hand lever of nozzle tester several times to bleed the air in the nozzle line, then move the hand lever at intervals of one stroke per second while reading the injection starting pressure.

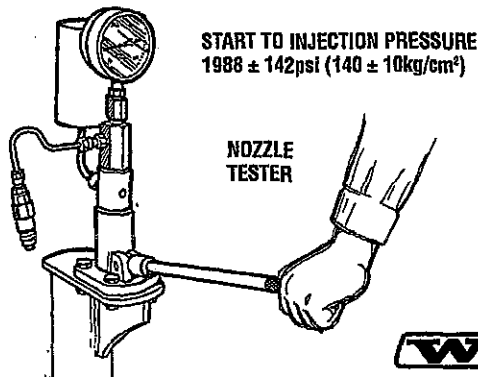

Inspecting Spray Pattern

1. Operate the hand lever of the nozzle tester one stroke per second to check if the fuel sprays directly in its axial direction. A nozzle is defective if it injects fuel in an oblique direction or in strips. Also, a spray in the form of particles is a defect. These defects may sometimes be caused by dust and, therefore, all parts should be cleaned before reassembly. (Care should be taken to expose one's skin to this spray as it may cause infection.)

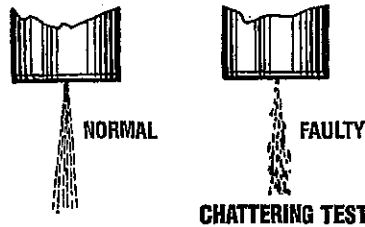

2. Apply the pressure of 1635 lb/in² (115 bar) by operating the hand lever, and check the nozzle tip. If it drips or has a large accumulation on the bottom, it is considered defective and should be replaced. A very small amount of fuel remaining on the tip of the nozzle; however, indicates a defect.

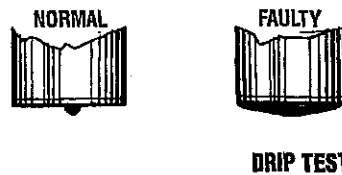

The injection starting pressure for the injector is increased or decreased by changing the thickness of the shim. The shim has 10 different thicknesses for (0.05 mm), between 0.0049in (1.25mm). With each 0.0020in (0.05mm) increase, the injection starting pressure increased approximately 71.1 lb/in² (5.0 kg/cm²). When replacing the shim, grip the retaining nut and remove the body with a wrench. Tighten to the specified torque.

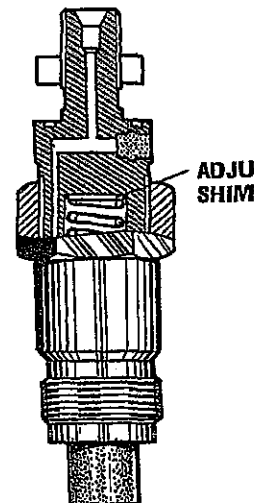

FUEL INJECTORS

REMOVING THE INJECTORS

NOTE: Injector must be serviced in a "clean room" environment.

1. Disconnect the high pressure lines from the injectors and loosen the lines at their attachment to the injection pump and move them out of the way of the injectors. Avoid bending the lines.
2. Using a 17mm long socket, remove the fuel return line in its entirety from the top of the injectors. Take care not to lose the two sealing washers and banjo bolt that attaches the fuel return line to each injector.

NOTE: Clean the area around the base of the injector prior to lifting it out of the cylinder head to help prevent any rust or debris from falling down into the injector hole. If the injector will not lift out easily and is held in by carbon build up or the like, work the injector side to side with the aid of the 17mm deep socket wrench to free it and then lift it out.

3. The injector seats in the cylinder head on a copper sealing washer. This washer should be removed with the injector and replaced with a new washer when the injector is reinstalled.

INJECTION TESTING

1. Using the nozzle tester, check the spray pattern and injection starting pressure of nozzle and, if it exceeds the limit, adjust or replace the nozzle. When using nozzle tester, take the following precautions:

CAUTION: The spray injected from the nozzle is of such velocity that it may penetrate deeply into the skin of fingers and hands, destroying tissue. If it enters the bloodstream, it may cause blood poisoning.

- a. If the diesel fuel of the nozzle tester is discolored, replace it. At the same time, clean or replace the filter.
- b. Set the nozzle tester in a clean place where there is no dust or dirt.
- c. Mount the nozzle and nozzle holder on the nozzle tester.
- d. Use the fuel at the approximate temperature of 68° F (20° C)
- e. Operate the hand lever of nozzle tester several times to bleed the air in the nozzle line, then move the hand lever at intervals of one stroke per second while reading the injection starting pressure.

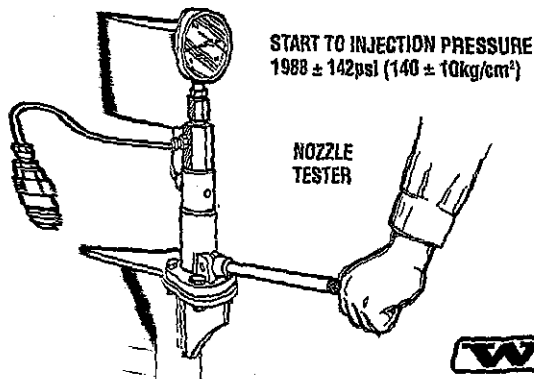

Inspecting Spray Pattern

1. Operate the hand lever of the nozzle tester at intervals of one stroke per second to check if the fuel is injected correctly in its axial direction. A nozzle is defective if it injects fuel in an oblique direction or in several separate strips. Also, a spray in the form of particles indicates a defect. These defects may sometimes be caused by clogging with dust and, therefore, all parts should be carefully cleaned before reassembly. (Care should be taken not to expose ones skin to this spray as it may penetrate the skin and cause infection.)

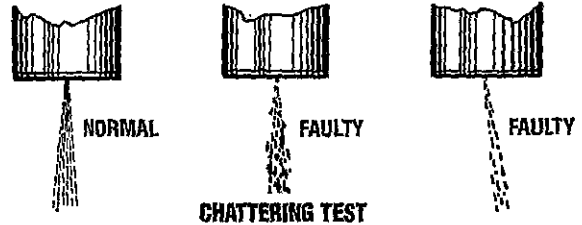

2. Apply the pressure of 1635 lb/in² (115 kg/cm²) to nozzle by operating the hand lever, and check the drips from the nozzle tip. If it drips or has a large accumulation of fuel on the bottom, it is considered defective and should be replaced. A very small amount of fuel may sometimes remain on the tip of the nozzle; however, this does not indicate a defect.



The injection starting pressure for the injectors is adjusted by increasing or decreasing the thickness of the adjusting shim.

The shim has 10 different thicknesses for every 0.0020 in (0.05 mm), between 0.0049in (1.25mm) to 0.0669in (1.7mm). With each 0.0020in (0.05mm) increase, injection pressure is increased approximately 71.1 lb/in² (5.0 kg/cm²). When replacing the shim, grip the retaining nut in a vise and remove the body with a wrench. Tighten the retaining nut to the specified torque.

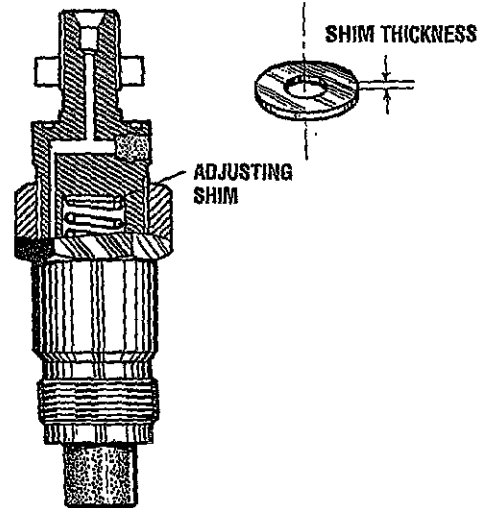

FUEL INJECTORS

DISASSEMBLING AND INSPECTING

1. Clamp the nozzle holder in a vise, then remove the cap nut.
2. Remove the pressure adjusting screw, then pull out the upper seat, spring and the push rod.
3. Clamp the nozzle holder in a vise, remove the nozzle nut then pull the nozzle out.
4. Clean the disassembled parts with clean diesel fuel, then remove the carbon adhering on the nozzle.

NOTE: Do not use a metal tool to remove the carbon.

5. After cleaning, check to see if the needle valve comes down into the valve seat by its own weight when setting the nozzle body upright position and inserting needle valve.
6. Check that there is no flaw or other damage on mating surfaces and sliding surfaces of the nozzle body and the needle valve and, if present, replace the nozzle assembly.

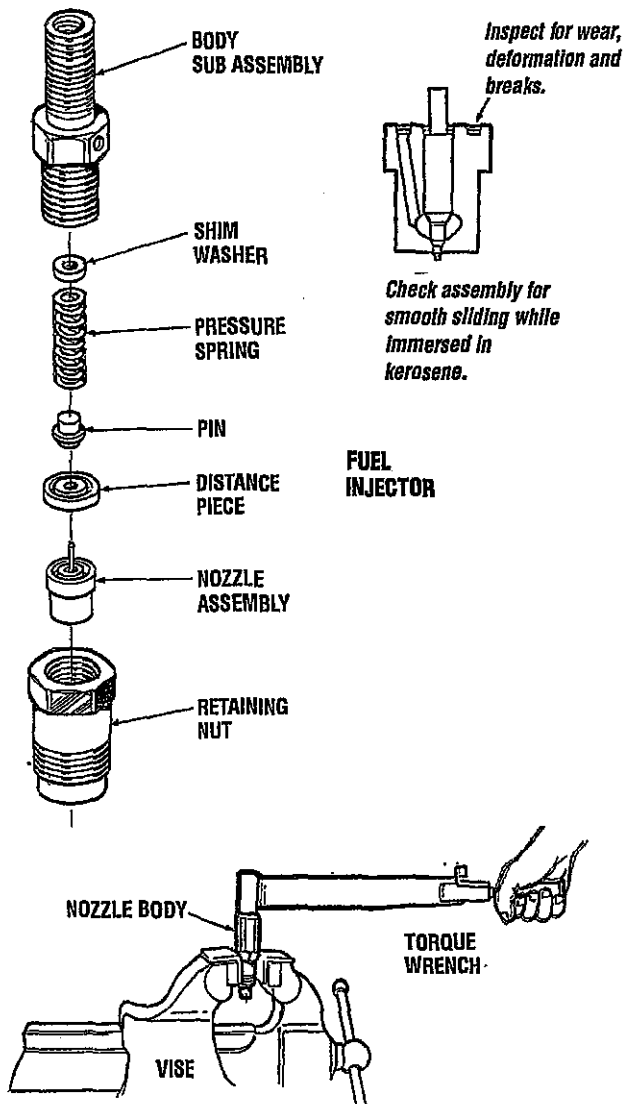

INSTALLING

Install the nozzle and nozzle holder assembly in the reverse order of removal. When installing the nozzle and nozzle holder assembly, use a new copper washer

ASSEMBLING

Assemble in the reverse order of disassembly, noting the following points:

1. To assemble the nozzle and nozzle holder, first assemble the pressure adjusting nut side, and temporarily tighten the nut. Mount the nozzle and set the needle valve to proper position, then mount the nozzle nut.
2. After the nozzle and nozzle holder have been assembled, check the injection starting pressure and spray condition.

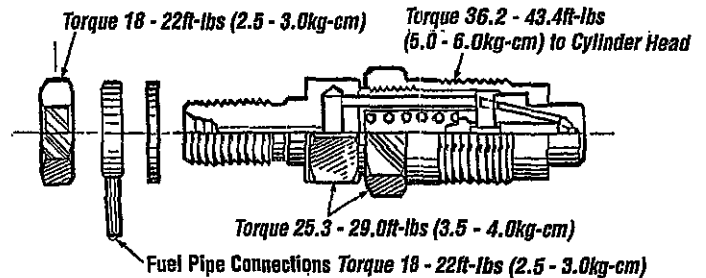

FUEL LIFT PUMPS

There is no maintenance required for the solid state fuel lift pump. This pump is activated during the start sequence when preheat is pressed. A distinct ticking can be heard when the pump is operating. If no ticking is heard, check the electrical connections. If the pump has failed, replace it.

Some early model generators and those generators equipped with 24 volt systems are equipped with a fuel lift pump which uses a replaceable filter. At overhaul, replace the filter and clean the pump exterior and the electrical connections. This pump, when operating properly, will also make a distinct ticking noise.

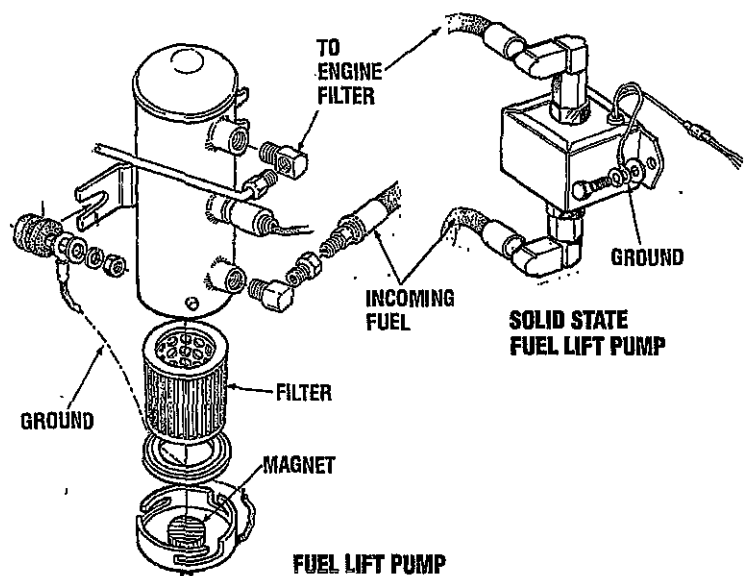

GLOW PLUGS

DESCRIPTION

The glow plugs are wired through the preheat solenoid. When PREHEAT is pressed at the control panel this solenoid should "click" on and the glow plug should begin to get hot.

INSPECTION

To inspect the plug, remove the electrical terminal connections, then unscrew or unclamp each plug from the cylinder head. Thoroughly clean each plug's tip and threads with a soft brush and cleaning solution to remove all the carbon and oil deposits. While cleaning, examine the tip for wear and burn erosion; if it has eroded too much, replace the plug.

TESTING

An accurate way to test glow plugs is with an ohmmeter. Touch one prod to the glow plug's wire connection, and the other to the body of the glow plug, as shown. A good glow plug will have a 1.0- to 1.5-ohm resistance. This method can be used with the plug in or out of the engine. You can also use an ammeter to test the power drain (8 to 9 amps per plug).

WARNING: *These glow plugs will become very hot to the touch. Be careful not to burn your fingers when testing the plugs*

Re-install the plugs in the engine and test them again. The plugs should get very hot (at the terminal end) within 20 to 25 seconds. If the plugs don't heat up quickly, check for a short circuit. When reinstalling the glow plugs, use anti-seize compound on the threads.

Glow Plug Tightening Torque 1.0 - 1.5 kg-m (7 - 11 lb-ft)

WARNING: *Do not keep a glow plug on for more than 30 seconds*

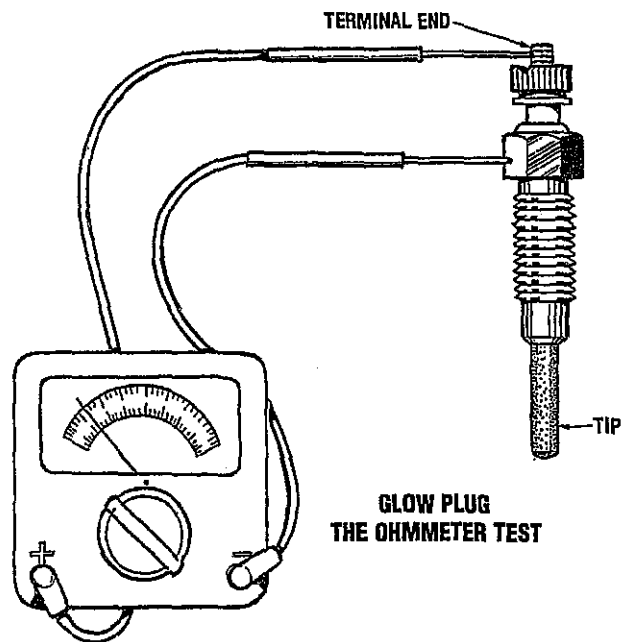

COOLANT CIRCULATING PUMP

DISASSEMBLY

1. Remove the pump pulley boss by using a support and press.
2. Remove the bearing shaft from the impeller and bearing housing by using a support block and press.
3. Remove the snap ring with snap ring pliers and press out the water pump shaft from the bearings.

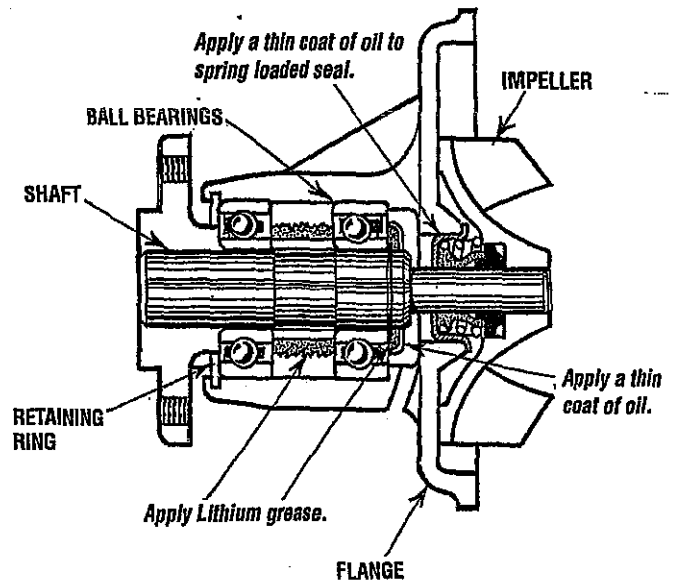
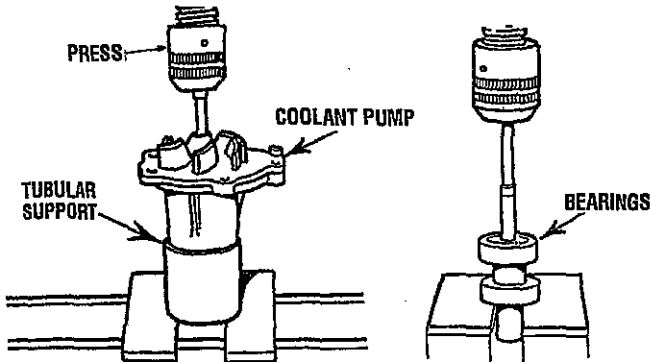

NOTE: Do not allow oil or grease to contaminate the surfaces of the ceramic ring or the graphite (small end) of the spring-loaded seal.

3. After the water pump has been assembled, check if the pump shaft rotates smoothly.

INSPECTION

Inspect the shaft, bearings and impeller. Look for cracks and damage. Check the housing gasket and inspect the rear seals and small end gaskets.

Replace any parts that show wear.

ASSEMBLY

Assemble the water pump in the reverse order of disassembly, using the following procedure:

1. Fill lithium grease (lithium base NLGI No. 2) into the following positions.
 - Ball bearings
 - Approximately 1/3 space between both ball bearings
 - Space between the ball bearing and water baffle plate.
2. Apply a thin coat of engine oil to the press fit surface of the water seal and press the larger end into the proper aperture of the pump using a tubular mandrel. (49 0636 145)

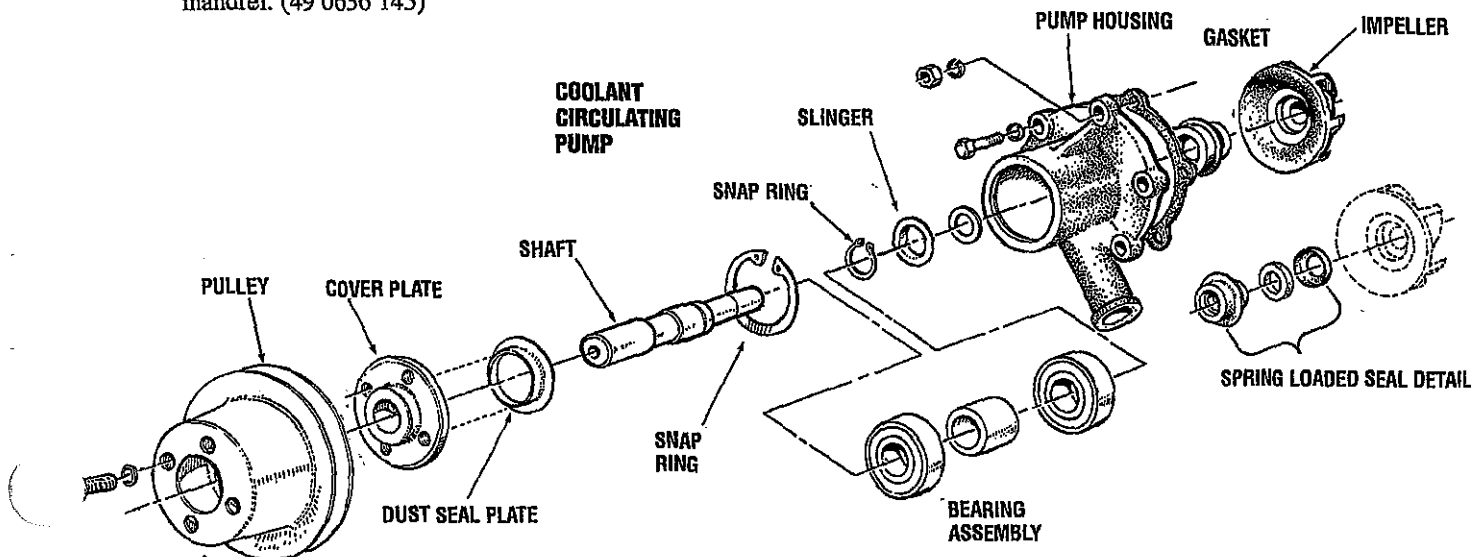
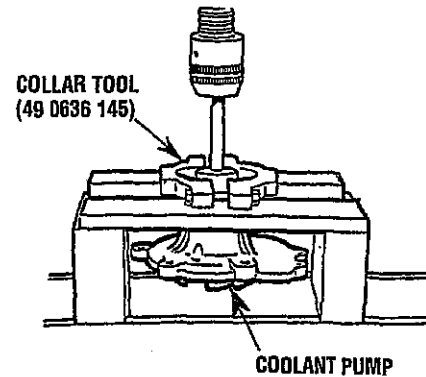

RAW WATER PUMP (PN. 48080)

Disassembly

NOTE: Refer to the following page for parts list and exploded view.

The pump, as removed from the engine, will have hose attachment nipples threaded into its inlet and outlet ports. They may be left in place or removed if they interfere with the pump disassembly. Note the port location and positioning if removed.

1. Remove the six cover plate screws, cover plate, and the cover plate gasket.
NOTE: Replacement of the cover plate gasket is recommended; however, if you are going to reuse it, keep the gasket submerged in water until the pump is reassembled. If it's allowed to dry, the gasket will shrink and not be reusable.
2. Remove the impeller with its drive screw from the pump housing.
3. Remove the screw and sealing washer and remove the cam from the pump housing.
4. Remove the wear plate and leave the pin in place.
5. Remove the front circlip, washer and water seal.
6. Remove the rear circlip
7. Support the pump housing at the mounting flange end. Using an arbor press and with a suitable drift, carefully press the shaft with bearings from the pump housing.
8. The slinger and oil seal will remain in the housing. Remove the oil seal and slinger.
9. Support the bearings inner race and push the shaft out of the bearings.

Inspection

Inspect all parts and replace those showing wear, cracks or corrosion.

Reassembly

1. Support the bearings inner race. Press the shaft into the bearings so that the drive end of the shaft extends beyond the second bearings inner race by 19/32" (15mm) 1/32" (.5mm)

NOTE: The seals' flat surfaces that have printing and numbers face toward each other.

2. Install the oil seal in the pump housing.
3. Support the pump. Lubricate the shaft and slide it thru the oil seal and press the bearings with shaft into the housing so that the outer bearing just clears the rear circlip retaining groove.
4. Install the rear circlip and press the shaft with bearings so that the outer bearing seats on the rear circlip.
5. Lubricate the slinger and slide it onto the shaft so that it is visible midway through the slotted openings of the pump housing.
6. Lubricate the inner half of the water seal, slide it over the shaft and seat it in the pump housing. Install the outer half, washer and front clip to hold the seal in place.
7. Install the wear plate and cam. Apply sealant (Permatex #1) to the cam screw threads and inner cam surfaces. Remove excess.
8. Lubricate and install the impeller. Blade positioning does not matter.
NOTE: Use the lubricant that comes with the impeller. Coat only the surface. Do not over-apply.
9. Install the O-ring and cover plate.

(continued)

RAW WATER PUMP (PN.48080)

PARTS LIST

KEY NO.	PART NUMBER AND PART NAME	QUANTITY
1	48080 RAW WATER PUMP	1
2	49172 SHAFT	1
3	49170 IMPELLER COVER	1
4	48500 IMPELLER KIT (O-RING & GLYCERIN)	1
5	34458 CAM	1
6	49171 WEAR PLATE	1
7	302575 DOWEL	1
8	48253 SPRING SEAL WASHER	1
9	34463 IMPELLER COVER SCREW	6
10	48359 IMPELLER COVER O-RING	1
11	33041 O-RING	1
12	33037 CAM WASHER	1
13	46662 CAM SCREW	1
14	48254 SPRING SEAL	1
15	49169 LIP SEAL	1
16	34464 BALL BEARING	2
17	33045 RETAINING INTERNAL RING	1
18	33044 RETAINING EXTERNAL RING	1
	49000 PUMP REPAIR KIT	1
	37431 PUMP KIT (MOUNTING GASKET & FITTINGS)	1

THE PUMP REPAIR KIT (49000) INCLUDES ALL THE LISTED COMPONENTS EXCEPT ITEMS 1 AND 7. THE KIT ALSO INCLUDES A PUMP MOUNTING GASKET.

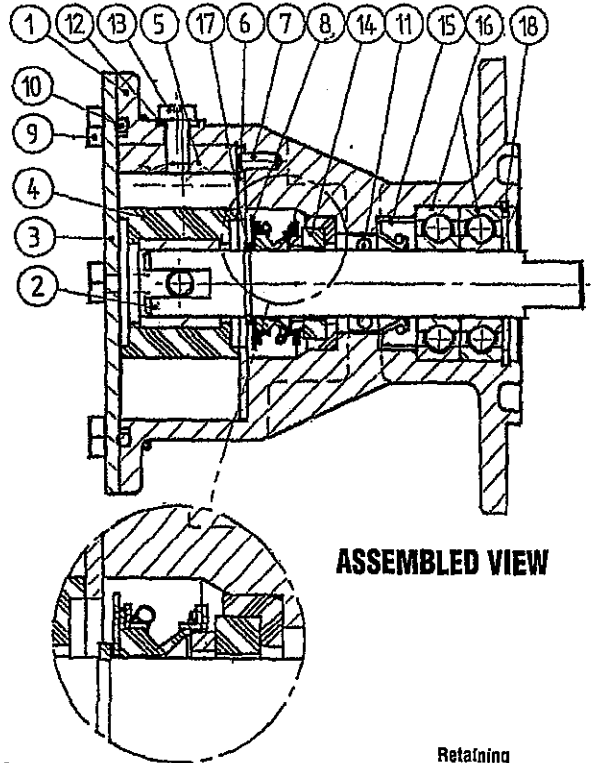

ASSEMBLED VIEW

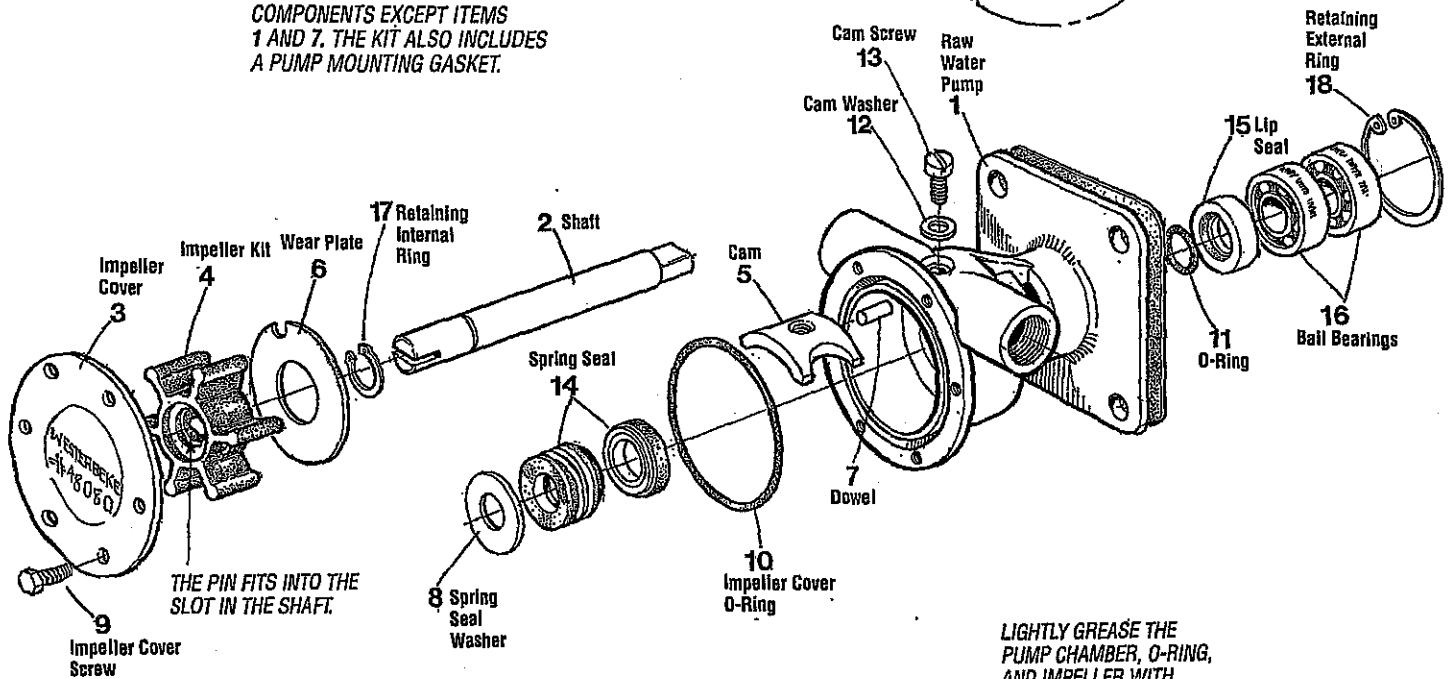

STARTER MOTOR

DESCRIPTION

The starter can be roughly divided into the following sections:

- A motor section which generates a drive power.
- An overrunning clutch section which transmits an armature torque, preventing motor overrun after starting.
- A switch section (solenoid) which is operated when actuating the overrunning clutch through a lever and which supplies load current to the motor.

The starter is a new type, small, light-weight and is called a high-speed internal-reduction starter. The pinion shaft is separate from the motor shaft; the pinion slides only on the pinion shaft. A reduction gear is installed between the motor shaft and a pinion shaft. The pinion sliding part is not exposed outside the starter so that the pinion may slide smoothly without becoming fouled with dust and grease. The motor shaft is supported at both ends on ball bearings. The lever mechanism, switch and overrunning clutch inner circuit are identical to conventional ones.

ADJUSTMENT AND REPAIR

If any abnormality is found by the following tests, the starter should be disassembled and repaired.

Pinion Gap Inspection

1. Connect a battery (12V) between the starter terminal S and the starter body, and the pinion drive should rotate out and stop.

CAUTION: Never apply battery voltage for over 10 seconds continuously.

2. Lightly push the pinion back and measure the return stroke (called pinion gap).
3. If the pinion gap is not within the standard range, (0.5 to 2.0 mm), adjust it by increasing or decreasing the number of shims on the solenoid. The gap is decreased as the number of shims increases.

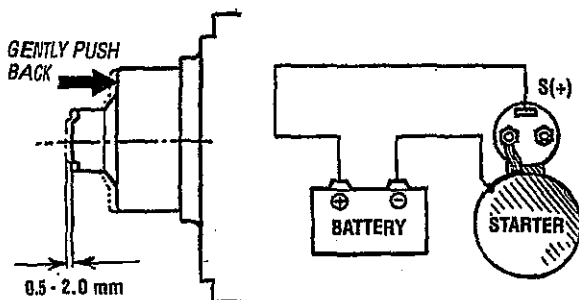

PINION GAP

No-Load Test

1. Connect the ammeter, voltmeter, and battery to the starter as illustrated.
2. When the switch is closed, the pinion must protrude and the starter must run smoothly (at 3000 rpm or more). If the current or starter speed is out of specification, disassemble the starter and repair it.

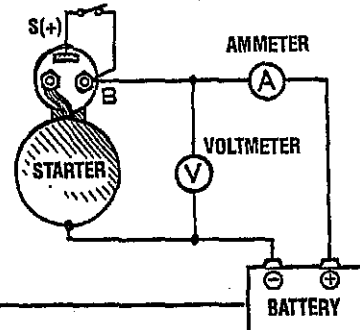

CAUTION: Use thick wires as much as possible and tighten every terminal securely. This is a solenoid shift-type starter which makes a rotating sound louder than that of a direct-drive type starter. When detecting starter rotation at the pinion tip, be careful not to come in contact with the pinion gear when it protrudes.

SOLENOID

Perform the following tests. If any test result is not satisfactory, replace the solenoid assembly.

1. Inspect the solenoid for continuity between terminals (+) and (-) and between terminals S and the body and M and the body. There should be no continuity found between terminals S and M. Continuity will be found between terminals S and the body and terminal M and the body.

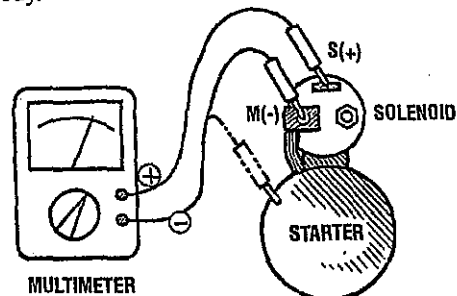

NOTE: Disconnect the wire from terminal M.

2. Connect a battery to the solenoid's terminal S for (+) and M for (-). Have a switch in the + lead and close it. The pinion drive should extend fully out.

CAUTION: Do not apply battery current for more than 10 seconds when testing the solenoid.

STARTER MOTOR

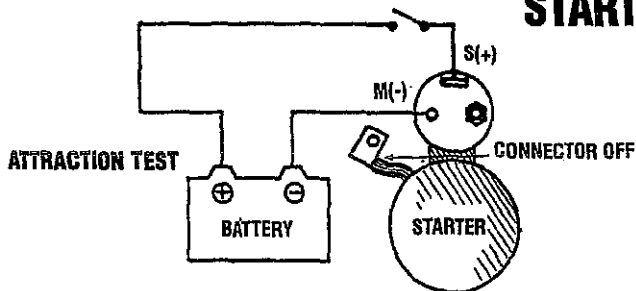

3. *Holding test.* With a battery connected to the solenoid terminal S (+) and to the starter body, manually pull out the pinion fully. The pinion must remain at that position even when released from holding with your hand.

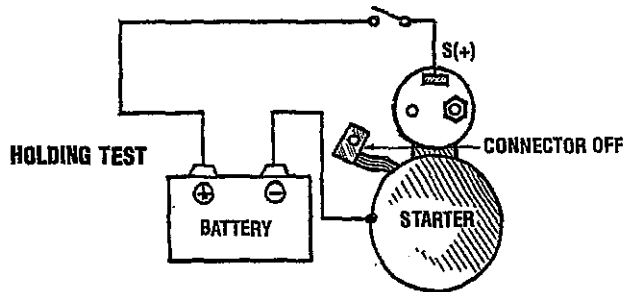

4. *Return test:* With a battery connected to the solenoid terminal M (-) and to the starter body, manually pull out the pinion fully. The pinion must return to its original position when released from holding by hand.

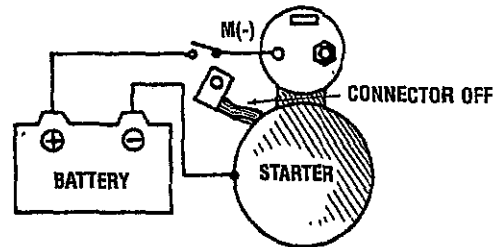

RETURN TEST

STARTER ASSEMBLY

1. Disconnect the wire from the solenoid terminal M (-).
2. Loosen the two screws fastening the solenoid. Remove the solenoid assembly.
3. Remove the two long through bolts and two screws fastening the brush holder. Remove the rear bracket.
4. With the brushes pulled away from the armature, remove the yoke and brush holder assembly. Then pull the armature out.
5. Remove the cover, pry the snap ring out, and remove the washer.
6. Unscrew the bolts and remove the center bracket. At the same time, the washers for the pinion shaft end play adjustment will come off.

7. Pull out the reduction gear lever and lever spring from the front bracket.
8. On the pinion side, pry the snap ring out, and pull out the pinion and pinion shaft.
9. At each end of the armature, remove the ball bearing with a bearing puller. It is impossible to replace the ball bearing press-fitted in the front bracket. If that bearing has worn off, replace the front bracket assembly.

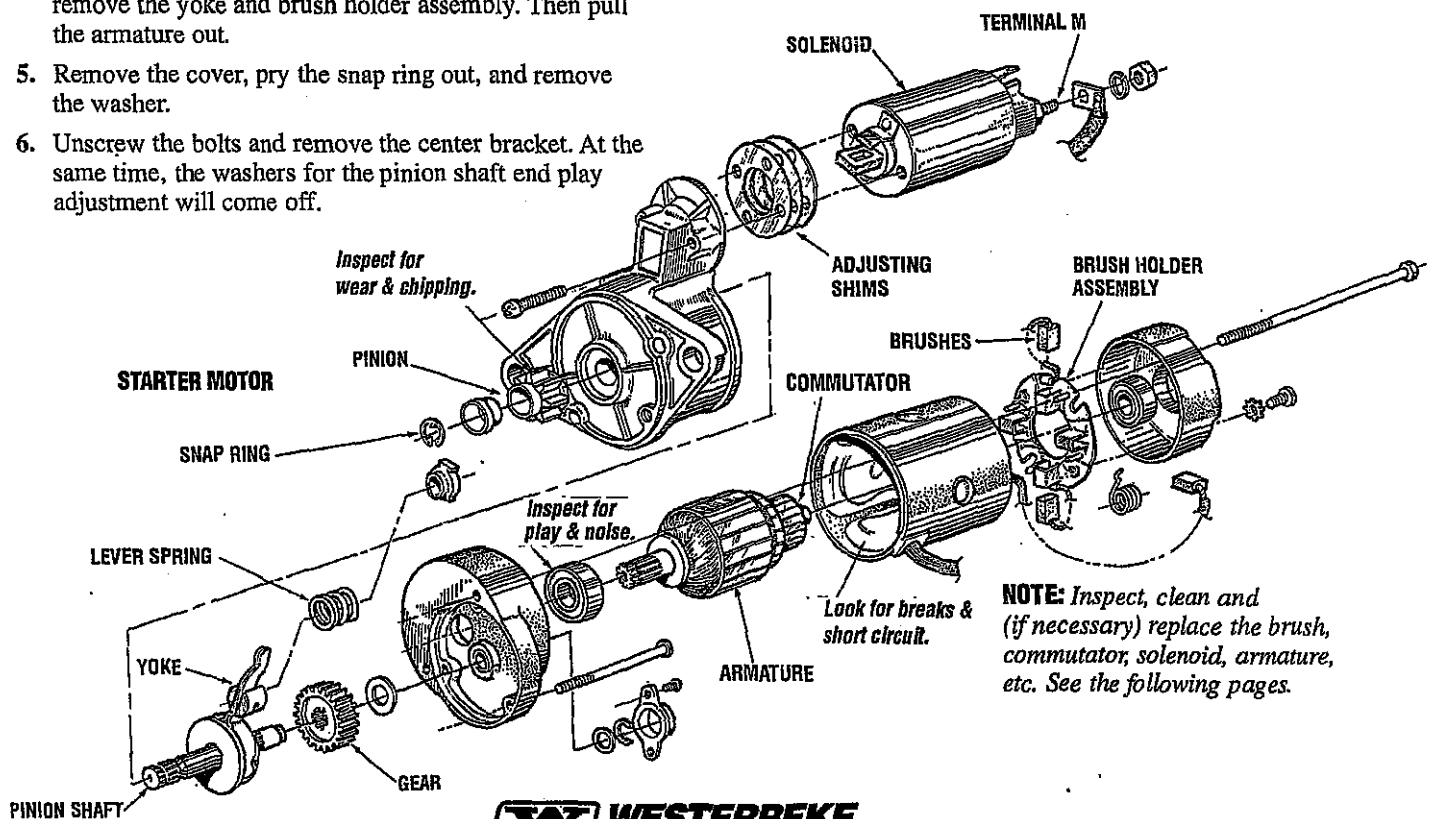

NOTE: *Inspect, clean and (if necessary) replace the brush, commutator, solenoid, armature, etc. See the following pages.*

STARTER MOTOR

STARTER INSPECTION

Solenoid

Inspect the solenoid for continuity between terminals S and M and between terminals S and body. No continuity should be found between S and M. Continuity should be found between S and the body and M and the body.

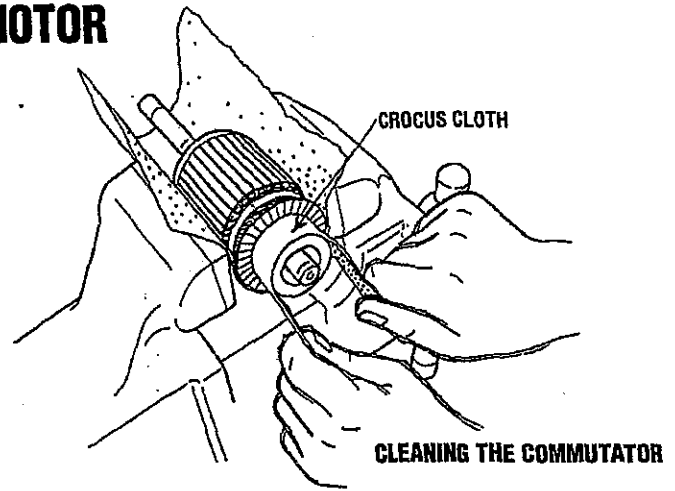
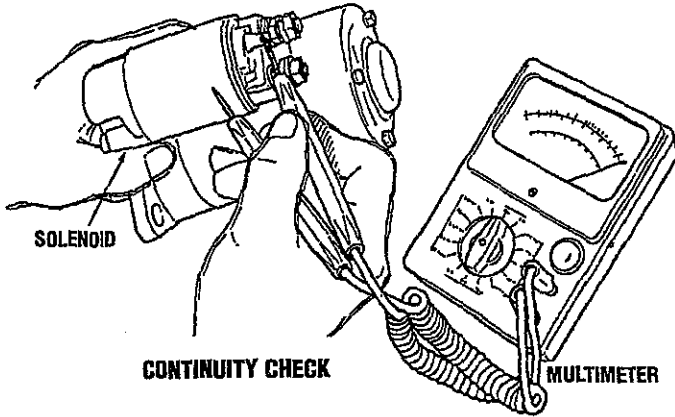

Brush and Brush Holder Inspection

1. Check the brushes. If worn out beyond the service limit, replace the brushes.

Brush Height
 Standard 17 mm (0.669 in)
 Limit 6 mm (0.236 in)

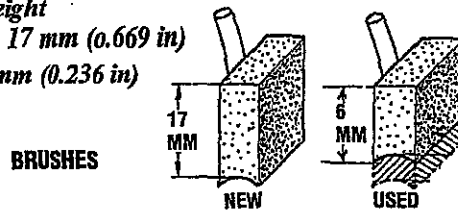

Inspecting The Armature

1. Check the armature with a growler tester. If it's short circuited, replace the armature. Also check for insulation between the commutator and its shaft. If poorly insulated, replace the armature.

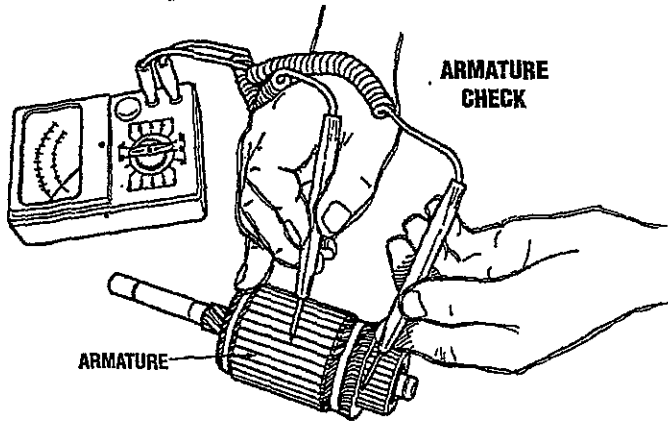

2. Check the brush spring tension. A weak or defective spring will cause excessive brush wear; replace the springs if suspect.

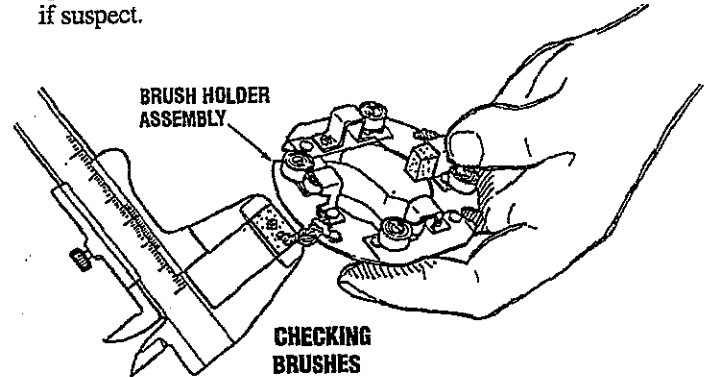

2. Measure the commutator O.D. and the depth of undercut. Repair or replace it if the service limit is exceeded. Also check the commutator outside surface for dirtiness and roughness. If rough, polish the commutator with fine crocus cloth.

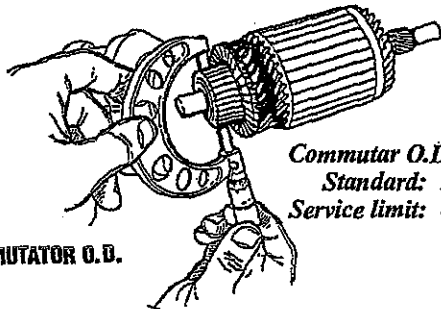

Commutator O.D. Standard
 Standard: 38.7 mm (1.523 in)
 Service limit: -1.0 mm (-0.039 in)

3. Check for insulation between the positive brush holder and holder base. If poorly insulated, replace the holder assembly. Also check the brush holders for proper staking.

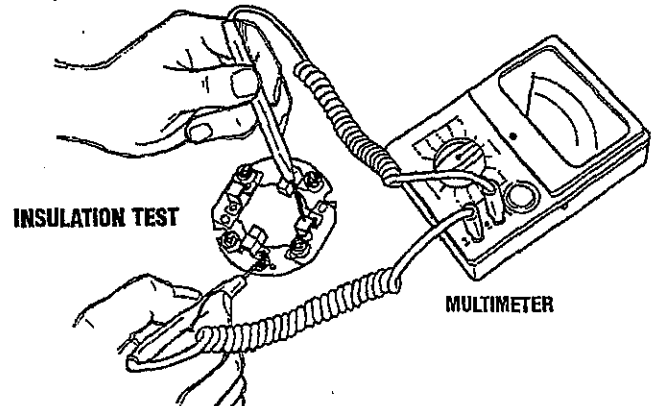

STARTER MOTOR

Field Coil Inspection

1. Check for insulation between one end (brush) of the coil and yoke.
2. Check for continuity between both ends (brushes) of the coil
3. Check the poles and coil for tightness.

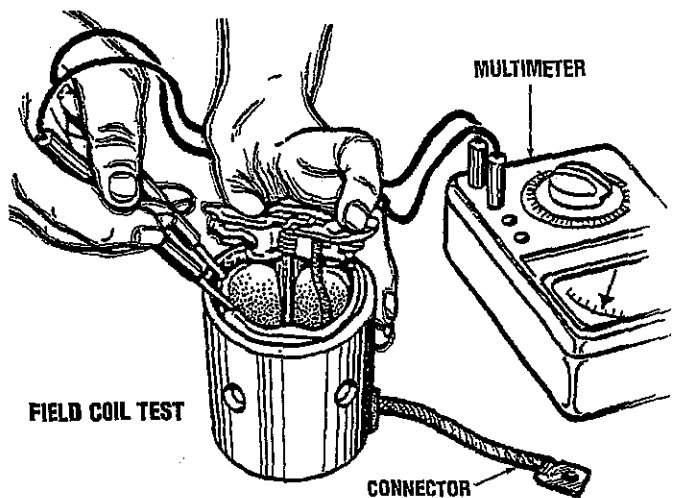

STARTER ADJUSTMENT AND REASSEMBLY

CAUTION: Before installing, thoroughly clean the starter flange and mounting surfaces, remove all oil, old paint, and rust. Starter performance largely depends on the quality of the wiring. Use wire of sufficient size and grade between the battery and starter and fully tighten to the terminal.

Reassemble the starter assembly in the reverse order of disassembly, making sure of the following:

1. *Pinion shaft end play adjustment.* Set the end play (thrust gap) to between 0.5 to 2 mm by inserting an adjusting washer between the center bracket and the reduction gear.
 - a. Fit the pinion shaft, reduction gear washer and snap ring to the center bracket.
 - b. Measure end play by moving the pinion shaft in the axial direction. If the end play exceeds 0.5 mm, increase the number of adjusting washers inserted.

2. *Greasing.* Whenever the starter has been overhauled, apply grease to the following parts:
 - a. Armature shaft gear and reduction gear.
 - b. All bearings.
 - c. Bearing shaft washers and snap rings.
 - d. Bearing sleeves.
 - e. Pinion.
 - f. Sliding portion of lever.

CAUTION: Never smear the starter fitting surface, terminals, brushes, or commutator with grease.

3. After reassembly, check by conducting a no-load test again.

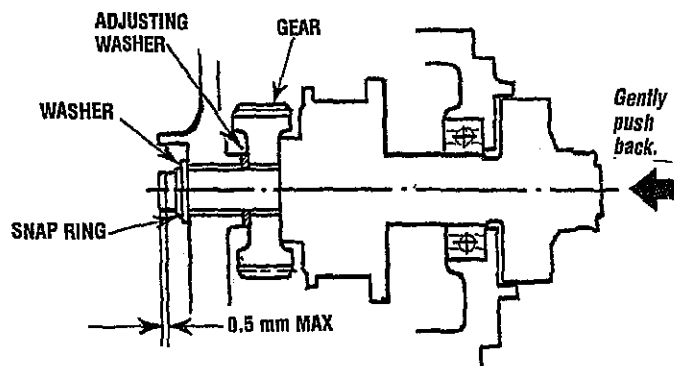

PINION SHAFT END PLAY

OIL PRESSURE

DESCRIPTION

The lubricating system is a pressure fed system using a gear style oil pump, driven off the front crankshaft and located in the front gear case. The engine oil is drawn from the oil sump by the oil pump, which delivers the oil under pressure, through the oil filter to various lubricating points in the engine. The oil then returns to the oil sump to repeat the cycle. When the oil pressure exceeds the specified pressure, the oil pushes open a pressure relief valve located in the front gear case and accessible and returns oil to the sump. Keeping the oil pressure within its specified psi range.

OIL PRESSURE

The engine's oil pressure is displayed on the LCD display screen during the units operation. During normal operation, the oil pressure may range between 35-55 psi (2.5 - 3.8 kg/cm) depending on the temperature and load.

LOW OIL PRESSURE

The specified safe minimum oil pressure at 1800/1500 rpm is 25 - 15 psi (1.75 - 1.05 kg/cm). A legitimate gradual loss of oil pressure can be the result of a faulty oil pressure relief valve or possibly worn bearings in the engine or even a faulty pressure sensor. Verify the oil pressure readings using a mechanical oil pressure gauge.

OIL PRESSURE RELIEF VALVE

An oil pressure relief valve is found just below the oil pressure sensor on the side of the front gear case.

OIL PRESSURE SENSOR

When performing an overhaul, it is recommended that the oil pressure sensor be replaced. When installing the new sensor, use some liquid Teflon sealant on the threads (only) of the new sensor. Use the correct size wrench to properly install the sensor and tighten securely. When test running the engine, pay particular attention to the fitting and connections the sensor is installed in to ensure there are no leaks.

The oil pressure sensor is mounted on a tee arrangement on the front gear case. It sends a low DC voltage signal to the ECU that is interpreted as pressure and is displayed on the LCD display screen. Should this voltage signal fall below a set point on the ECU, the ECU will open the K2 run relay and shut the unit down. The LCD display failure red LCD light will illuminate, the oil pressure LED will turn amber and the screen will display the fault test *Low Oil Pressure*. Oil pressure dropping to 10-15 psi will cause this to occur.

TESTING OIL PRESSURE

To test the oil pressure, remove the oil gallery "T" plug and install a mechanical oil pressure gauge in its place. After warming up the engine, read the oil pressure gauge.

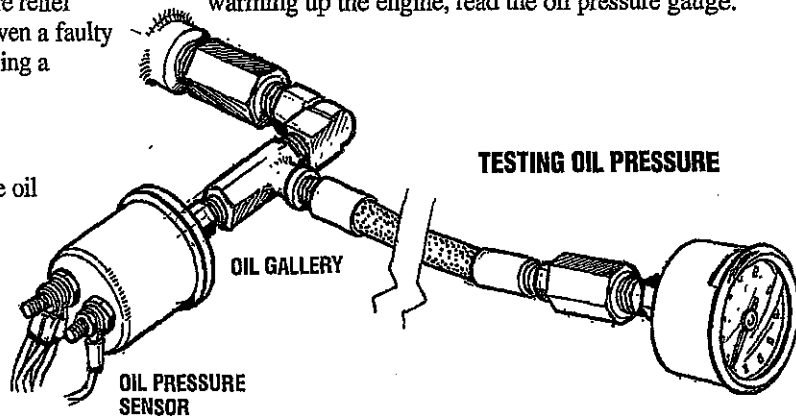

ENGINE ADJUSTMENTS

VALVE CLEARANCE ADJUSTMENT

NOTE: Retorque the cylinder head bolts before adjusting the engine's valves. See TORQUING THE CYLINDER HEAD BOLTS.

⚠ WARNING: Adjust the valve clearance when the engine is cold. Valves are adjusted by cylinder in the firing order of the engine. Tighten the cylinder head bolts to the specified torque before adjusting the valves.

Pull off the air breather pipe from the rocker cover and take off the rocker cover bolts and the rocker cover to expose the rocker shaft and valve assembly.

Remove the glow plugs from each of the cylinders to enable the crankshaft to be easily rotated by hand to position each cylinder for valve adjustment.

Valves are adjusted with the cylinder in the piston being adjusted at Top Dead Center (TDC) of its compression stroke. Each cylinder is adjusted following the engine's firing order (1-3-2 for WESTERBEKE three cylinder engines).

Valve adjustment beginning with cylinder #1. Rotate the crankshaft slowly and observe the operation of the valves for cylinder #1. Watch for the intake valve to open indicating the piston is on its intake stroke (the piston is moving down in the cylinder). Continue to rotate the crankshaft slowly and look for the intake valve to close. This indicates the piston is now starting its compression stroke (the piston is moving up in the cylinder towards TDC).

Align the TDC mark on the crankshaft front pulley with the timing marker on the front gear case cover when positioning the #1 Piston at TDC of its compression stroke. Confirm this by rotating the crankshaft approximately 20 degrees before and after this point and the two valves for the #1 cylinder should not move.

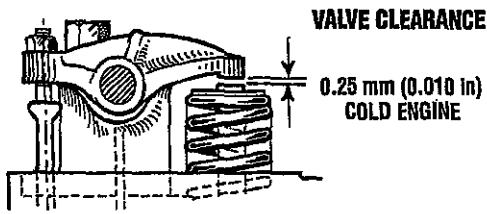

Adjust the valves in #1 cylinder for both intake and exhaust. Proceed to the next cylinder in the firing order.

Rotate the crankshaft 240 degrees in the normal direction of rotation and adjust the next cylinder's valves in the firing order. Rotate the crankshaft another 240 degrees and adjust the valves of the next cylinder in the firing order.

Adjust each valve's clearance by inserting a 0.010in (0.25mm) feeler gauge between the rocker arm and the valve stem. Make sure to adjust all valves while the engine is cold.

Re-install the glow plugs (use anti-seize compound on the threads) and assemble the rocker cover and rocker cover bolts. See TIGHTENING TORQUE SCHEDULE in this manual.

ENGINE COMPRESSION

Check the compression pressure. To do this warm the engine, remove all fuel injectors, or glow plugs, disconnect the fuel shut-off solenoid wire, and install a compression adapter in the injector hole or glow plug hole. Connect a compression tester on the adapter and crank the engine with the starter motor until the pressure reaches a maximum value. Repeat this process for each cylinder. Look for cylinders with dramatically (at least 20%) lower compression than the average of the others. Compression pressure should not differ by more than 35.5 psi (2.5 kg/cm²) at 280 rpm.

Standard compression pressure 398 lb/in² at 280 rpm (28.0 kg/cm²)

If a weak cylinder is flanked by healthy cylinder, the problem is either valve or piston related. Check the valve clearances for the weak cylinder, adjust as needed and test again. If the cylinder is still low, apply a small amount of oil into the cylinder to seal the rings and repeat the test. If compression comes up - the rings are faulty.

Abnormally high readings on all cylinders indicates heavy carbon accumulations, a condition that might be accompanied by high pressures and noise.

NOTE: In case of severe vibrations and detonation noise, the cause may be fuel injector problems, see FUEL INJECTORS. Poor fuel quality, contaminates and loss of positive fuel pressure to the injection pump will result in injector faults.

When re-installing the glow plugs use anti-seize compound.

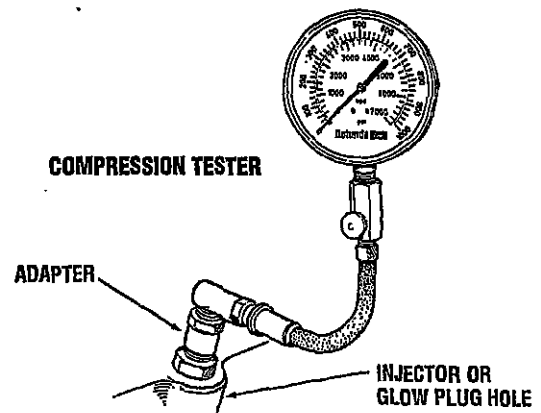

ALTERNATORS TESTING/TROUBLESHOOTING

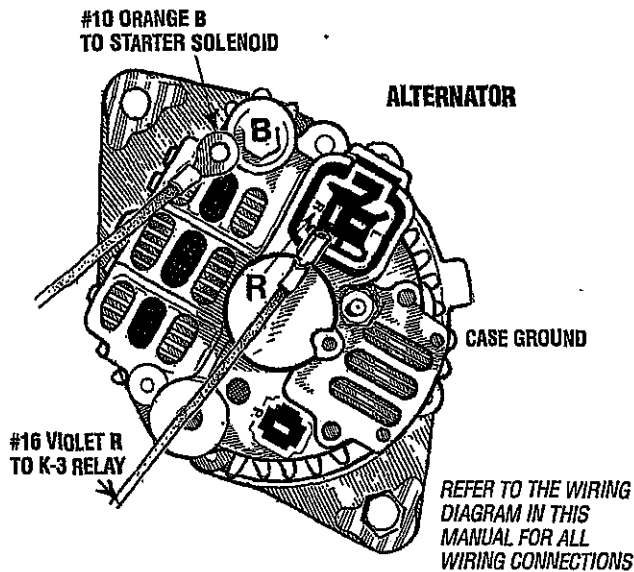

DESCRIPTION

The following information applies to the standard alternators that are supplied with WESTERBEKE'S Engines and Generators.

ELECTRICAL CHARGING CIRCUIT

The charging system consists of an alternator with a voltage regulator, an engine DC wiring harness, a mounted DC circuit breaker and a battery with connecting cables. Because of the use of integrated circuits (IC's), the electronic voltage regulator is very compact and is mounted internally or on the back of the alternator.

It is desirable to test the charging system (alternator and voltage regulator) using the wiring harness and electrical loads that are a permanent part of the system and will then provide the technician with an operational test of the charging system as well as the major components of the electrical system.

ALTERNATOR DESCRIPTION

The stator is connected to a three-phase, full-wave bridge rectifier package which contains six diodes. The bridge converts the AC generated in the stator to a DC output for battery charging and accessories.

Power to the regulator and the field of the integral regulator alternator is provided by the field diode (or diode trio) package contained in the alternator.

These alternators produce a rated output of 50 or 51 amps. rated output is achieved at approximately 6000 alternator rpm at an ambient temperature of 75°F (23.8°C). The alternators are designed to operate in an ambient temperature range of -40° to 212°F (-40° to 100°C).

VOLTAGE REGULATOR

The integral voltage regulator is an electronic switching device which senses the system voltage level and switches the voltage applied to the field in order to maintain a proper system voltage.

The regulator design utilizes all-silicon semi conductors and thick-film assembly techniques. After the voltage has been adjusted to the proper regulating value, the entire circuit is encapsulated to protect the circuit and the components from possible damage due to handling or vibration.

ALTERNATOR TROUBLESHOOTING

Use this troubleshooting section to determine if a problem exists with the charging circuit or with the alternator. If it is determined that the alternator or voltage regulator is faulty, have a qualified technician check it.

WARNING: A working alternator runs hot. A failed alternator can become very hot. Do not touch the alternator until it has cooled.

LOW BATTERY/FAULTY CIRCUIT

If the starter only moans or makes a clicking sound instead of spinning the engine to life it is likely a low battery or a faulty connection in the starting circuit and not an alternator problem.

PRELIMINARY INSPECTION

Before starting the actual alternator and voltage regulator, testing the following checks are recommended.

1. Make certain your alternator is securely mounted.
2. Check the drive belts for proper tension. Replace the belt if it is worn or glazed.
3. Check that all terminals, connectors and plugs are clean and tight. Loose or corroded connections cause high resistance and this could cause overcharging, undercharging or damage to the charging system. Badly corroded battery cables could prevent the battery from reaching a fully charged condition.
4. Check the condition of the battery and charge if necessary. A low or discharged battery may cause false or misleading readings in the tests.

NOTE: An isolator with a diode, a solenoid, or a battery selector switch is usually mounted in the circuit to isolate the batteries so the starting battery is not discharged along with the house batteries. If the isolator is charging the starting battery but not the house battery, the alternator is OK and the problem is in the battery charging circuit.

ALTERNATORS TESTING/TROUBLESHOOTING

TESTING THE ALTERNATOR

CAUTION: Before starting the engine make certain that everyone is clear of moving parts! Keep away from sheaves and belts during test procedures.

1. Start the Engine.
2. After the engine has run for a few minutes, measure the starting battery voltage at the battery terminals using a multimeter set on DC volts.
 - a. If the voltage is increasing toward 14 volts, the alternator is working.
 - b. If the voltage remains around 12 volts, a problem exists with either the alternator or the charging circuit; continue with Steps 3 through 6.

MEASURING BATTERY VOLTAGE (ENGINE RUNNING)

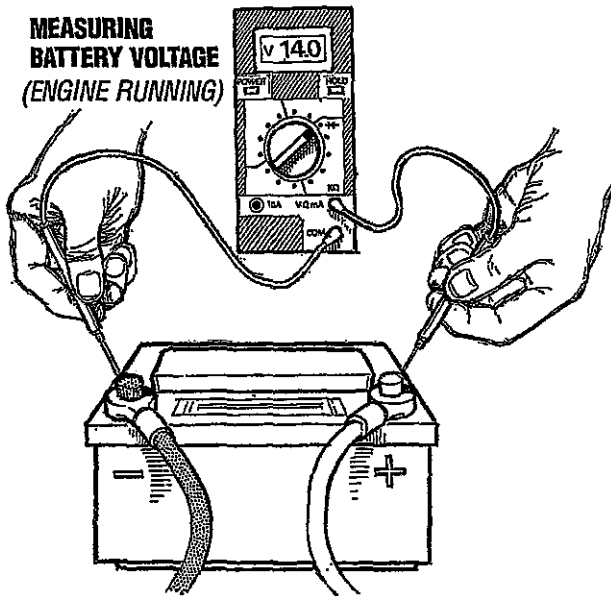

3. Turn off the engine. Inspect all wiring and connections. Ensure that the battery terminals and the engine ground connections are tight and clean
4. If a battery selector switch is in the charging circuit, ensure that it is on the correct setting.
5. Turn on the ignition switch, but do not start the engine.
6. Check the battery voltage. If your battery is in good condition the reading should be 12 to 13 volts.

MEASURING BATTERY VOLTAGE (IGNITION ON ENGINE OFF)

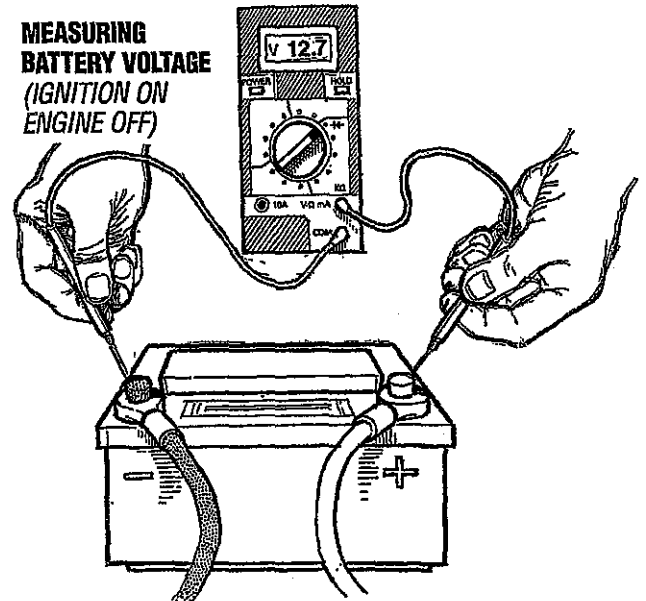

TESTING THE OUTPUT CIRCUIT

1. Connect the positive probe to the output terminal B and connect the negative probe to ground.
2. Wiggle the engine wiring harness while observing the voltmeter. The meter should indicate the approximate battery voltage, and should not vary. If no reading is obtained, or if the reading varies, check the alternator output circuit for loose or dirty connections or damaged wiring.
3. Start the engine.
4. Repeat the same measurement, the negative probe to ground, the positive probe to B with the engine running. The voltage reading should be between 13.5 and 14.5 volts. If your alternator is over or under-charging, have it repaired at a reliable service shop.
5. If the previous test reads only battery voltage at terminal B, use the meter to measure the DC excitation terminal. If 12 volts is not present at exciter terminal R, inspect the wiring for breaks and poor connections. Jump 12 volts from a 12 volt source (such as the battery) and operate the alternator. If the voltage output is 13-14 volts, . . then the alternator is OK.

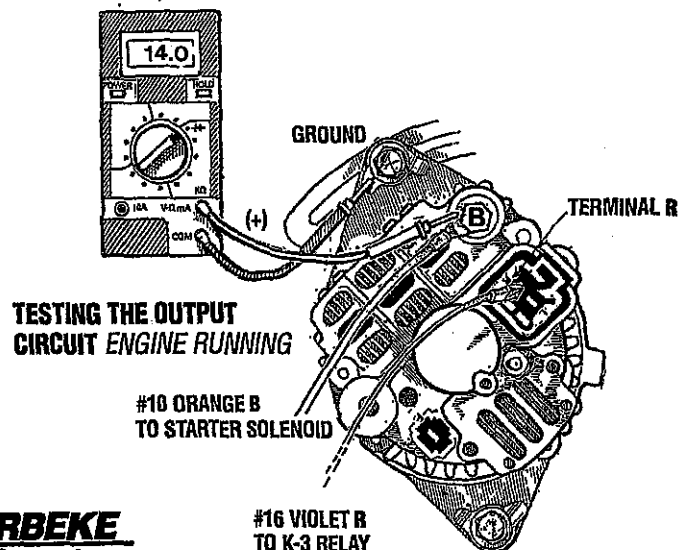

ALTERNATORS TESTING/TROUBLESHOOTING

TESTING THE EXCITATION CIRCUIT

1. Connect the positive (+) multimeter probe to the excitation terminal R on the alternator and the negative (-) lead to ground.
2. Turn the ignition switch to the on position and note the multimeter reading. The reading should be 1.3 to 2.5 volts (see illustration).

TESTING THE EXCITATION CIRCUIT (ENGINE RUNNING)

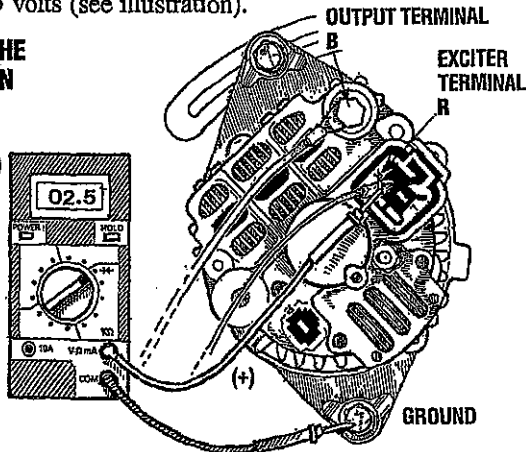

3. If the reading is between .75 and 1.1 volts, the rotor field circuit probably is shorted or grounded.
4. If the reading is between 6.0 and 7.0 volts, the rotor field circuit probably is open.
5. If no reading is obtained, an open exists in the alternator-excitation lead or in the excitation circuit of the regulator. Disconnect the lead from exc terminal R. Connect the positive multimeter probe to the excitation lead and the negative multimeter probe to ground. If the multimeter now indicates an approximate battery voltage, the voltage regulator is defective and must be replaced. If no voltage is indicated, check the excitation circuit for loose or dirty connections or damaged wiring.

TESTING THE EXCITATION CIRCUIT ENGINE RUNNING

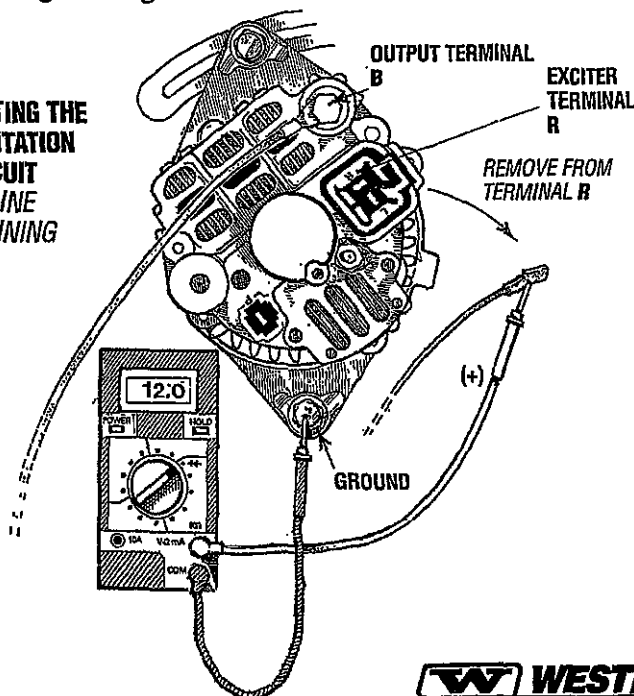

CHECKING THE SERVICE BATTERY

Check the voltage of the service battery. This battery should have a voltage between 13 and 14 volts when the engine is running. If not, there is a problem in the service battery charging circuit. Troubleshoot the service battery charging circuit by checking the wiring and connections, the solenoid, isolator, battery switch, and the battery itself.

When the problem has been solved and before the alternator is back in operation, take the time to tighten and clean the terminal studs. Also clean the connecting terminals from the wiring harness.

ALTERNATOR REPAIR

If tests indicate a failed alternator, it will need to be disassembled and repaired. Any good alternator service shop can do the job.

NOTE: WESTERBEKE'S Service Manual has detailed instructions for the disassembly and repair of their standard alternators.

BATTERY CARE

The minimum recommended capacity of the battery used in the engine's 12 volt DC control circuit is 600 -- 900 Cold Cranking Amps (CCA).

Review the manufacturer's recommendations and then establish a systematic maintenance schedule for your engine's starting batteries and house batteries.

- Monitor your voltmeter for proper charging during engine operation.
- Check the electrolyte level and specific gravity with a hydrometer.
- Use only distilled water to bring electrolytes to a proper level.
- Make certain that battery cable connections are clean and tight to the battery posts (and to your engine).

DIGITAL CONTROL BOX

GENERATOR FREQUENCY ADJUSTMENT (HERTZ)

CAUTION: When changing the generator frequency setting on the ECU. Turn off the 20 amp DC breaker on the control box. Turn it back on after the setting has been changed.

FREQUENCY FAULT

Frequency is displayed on the LCD display screen while the engine is running in RPM and frequency (hertz).

The ECU is receiving a low AC voltage signal and hertz signal from the MPU which is positioned on the bellhousing over the flywheel ring gear teeth. The ECU interprets this signal as both RPM and hertz.

Should this signal vary approximately 2-% either up or down, a frequency fault shut down will occur, initiated by the ECU. The red failure LED on the display panel will illuminate, the frequency LED will turn from green to amber and the LCD display screen will show the fault text "overspeed".

NOTE: If the unit shuts down for an underspeed condition, the same fault test "overspeed" will show on the screen, but the frequency LED will BLINK.

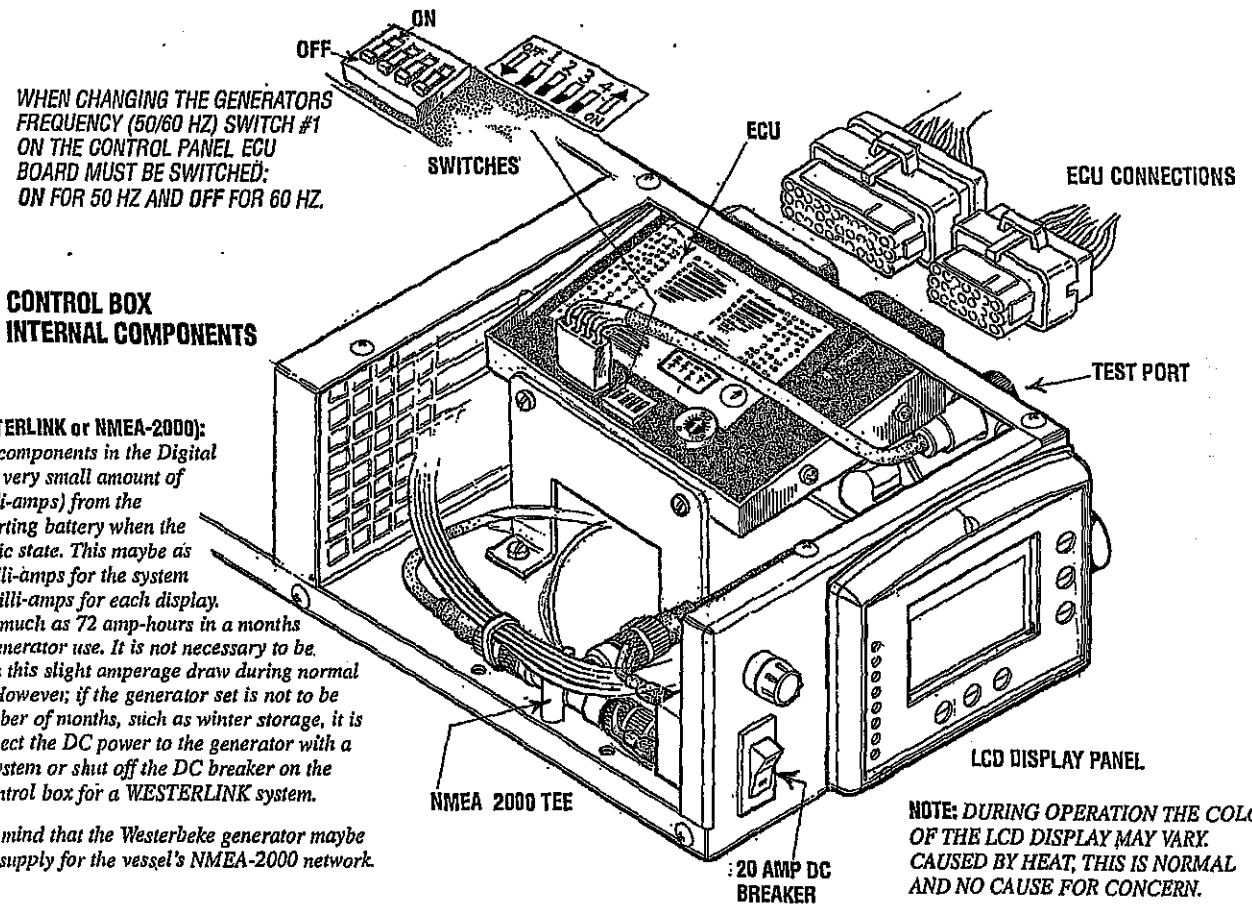

CONTROL BOX INTERNAL COMPONENTS

CAUTION (WESTERLINK or NMEA-2000): The electronic components in the Digital Diesels draw a very small amount of amperage (milli-amps) from the generator's starting battery when the unit is in a static state. This may be as much as 50 milli-amps for the system ECU and 50 milli-amps for each display. This can be as much as 72 amp-hours in a months time with no generator use. It is not necessary to be concerned with this slight amperage draw during normal seasonal use. However, if the generator set is not to be used for a number of months, such as winter storage, it is best to disconnect the DC power to the generator with a NMEA-2000 system or shut off the DC breaker on the generator's control box for a WESTERLINK system.

NOTE: Keep in mind that the Westerbeke generator maybe the DC power supply for the vessel's NMEA-2000 network.

NOTE: DURING OPERATION THE COLOR OF THE LCD DISPLAY MAY VARY. CAUSED BY HEAT, THIS IS NORMAL AND NO CAUSE FOR CONCERN.

7.6KW/5.5KW GENERATOR WIRING DIAGRAM #52414

7.6KW/5.5KW GENERATOR WIRING DIAGRAM #52414

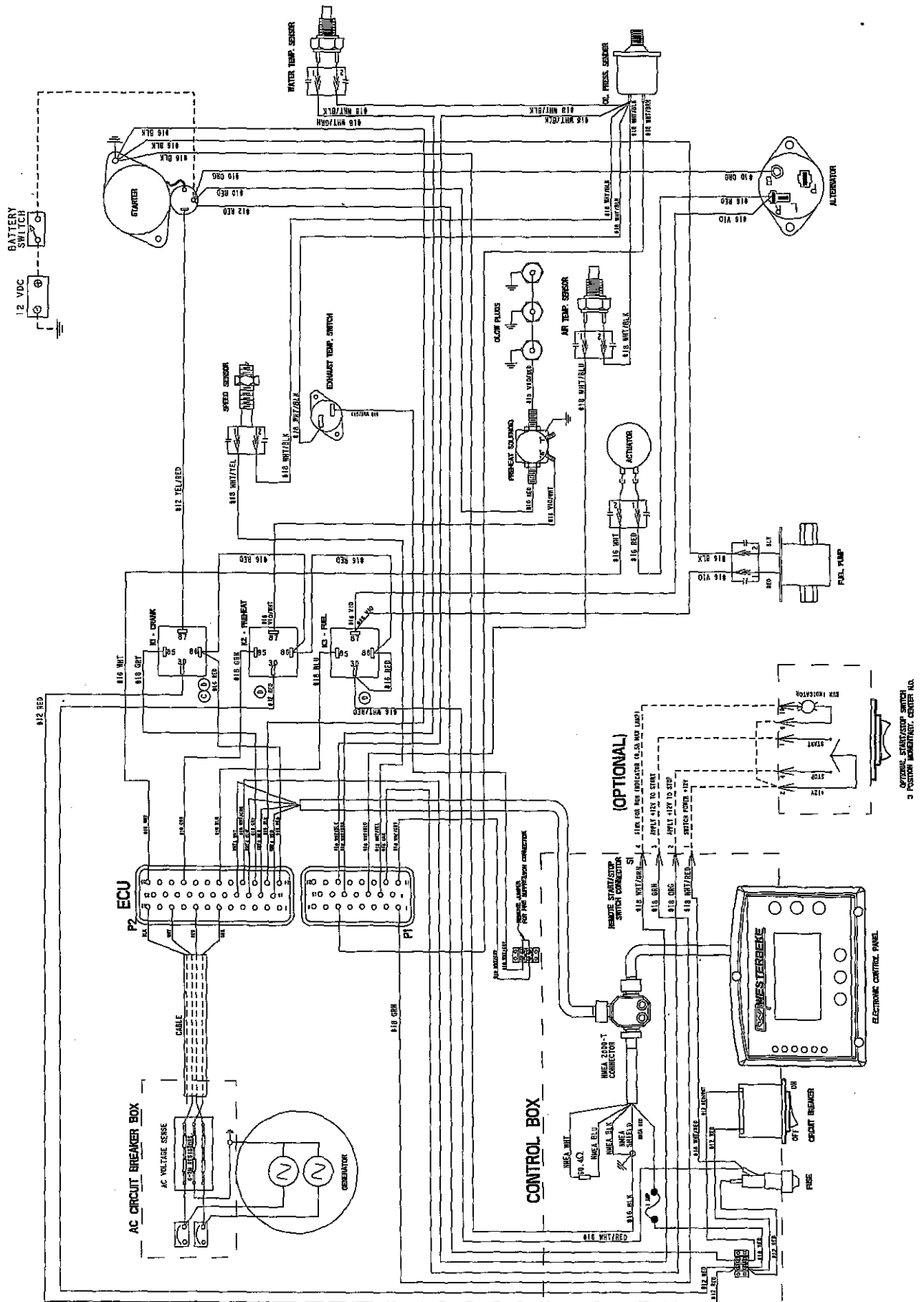

SPECIFICATIONS - 7.6/5.7KW EDT GENERATOR

ENGINE SPECIFICATIONS	
Engine Type	Diesel, four-cycle, three-cylinder, fresh water-cooled, vertical in-line overhead valve mechanism (11 Hp at 1800 rpm maximum).
Aspiration	Naturally aspirated
Governor	Electronic
Combustion Chamber	Swirl type
Bore & Stroke	2.99 x 2.76 inches (76 x 70 mm)
Piston Displacement	59.09 cubic inches (0.952 liters)
Firing Order	1 - 3 - 2
Direction of Rotation	Clockwise, when viewed from the front
Compression Ratio	23 : 1
Weight	407 lbs (185 kgs)
Fuel Consumption	
1800 rpm F/L	0.78 gph (2.9 lph)
1500 rpm F/L	0.58 gph (2.2 lph)
Inclination	Continuous 25° in all directions Temporary 30° (not to exceed 30 min.)
Generator Power Take Off	11 Hp @ 1800 rpm 9 Hp @ 1500 rpm

TUNE-UP SPECIFICATIONS	
Compression Pressure (Limit of Difference Between Cylinders)	398 psi (28 kg/cm ²) at 280 rpm limit (47.2 psi (3.0 kg/cm ²))
Valve Timing	Intake Opens 17° BTDC Intake Closes 47° ABDC Exhaust Opens 51° BBDC Exhaust Closes 13° ATDC
Spill Timing (Static)	15° BTDC ± .5°
Valve Seat Angle	Intake 45° Exhaust 45°
Engine Speed	1800 rpm 60 Hertz 1500 rpm 50 Hertz
Valve Clearance (engine cold)	Intake and Exhaust 0.010 Inches (0.25 mm)
Injector Pressure	1920 + 71 - 0 psi (135 + 5 - 0 kg/cm ²)

FUEL SYSTEM	
General	Open flow, self bleeding - self priming
Fuel	No. 2 diesel oil (cetane rating of 45 or higher)
Fuel Injection Pump	In-line plunger, Bosch type
Nozzle	Cartridge type
Fuel Filter	Spin-on type
Air cleaner	Air flow silencer system
Air Flow (engine combustion)	24.6 cfm (0.697 cmm)

ELECTRICAL SYSTEM	
Starting Battery	12-Volt, (-) negative ground
Battery Capacity	800 - 1000 Cold Cranking Amps (CCA)
DC Charging Alternator	50 Amp rated, belt driven
Starter	12-Volt, reduction gear, 1.2 KW
Starting Aid	Glow plugs, sheathed type
DC No-Load Current	± 2% of rated amps
DC Cranking Current	150 - 175 Amps (engine cold)

COOLING SYSTEM	
General	Fresh water-cooled block, thermostatically-controlled with heat exchanger.
Operating Temperature	170 - 190° F (77 - 88° C)
Fresh Water Pump	Centrifugal type, metal impeller, belt-driven
Raw Water Pump	Positive displacement, rubber impeller, gear-driven.
Raw Water Flow, at 1800 rpm	6.5 US gpm (25.8 lpm) (measured before discharging into the exhaust elbow).
System Capacity (fresh water)	4.0 qts (3.79 liters)

LUBRICATION SYSTEM	
General	Pressure fed system with external relief valve
Oil Filter	Full flow, paper element, spin-on type
Sump Capacity (not including filter)	3.2 U.S. qts (3.03 liters) plus filter/cooler assembly
Operating Oil Pressure (engine hot)	35 - 55 psi (2.5 - 3.8 kg/cm ²)
Oil Grade	API Specification CF or CG-4, SAE 30, 10W-30, 15W-40

AC GENERATOR (SINGLE PHASE)	
General - Single Phase	Brushless, four-pole, revolving field sealed lubricated single bearing design. Reconnectable single phase for 120/240 volts with solid state voltage regulator.
Voltage - Single Phase	120 or 120/240 Volts - 60 Hertz 230 Volts - 50 Hertz
Voltage Regulation	±5% no load to full load
Frequency Regulation	±0.05 Hertz no load to full load
Rating (Volts AC)	7.6 KW - 60 Hertz (1800 rpm) 120 Volts - 63.3 amps 120/240 Volts - 63.3/31.7 amps 5.7 KW - 50 Hertz (1500 rpm) 230 Volts - 24.8 Amps

GENERATOR COOLING	
Air Requirements (60 Hertz @ 1800 rpm)	200 cfm (5.66 cmm)
Note: Increase air supply 15% for 50 Hertz operation @ 1500 rpm	
Engine Combustion Air Requirements (60 Hertz @ 1800 rpm)	31.2 cfm (0.57 cmm)
NOTE: Forced ventilation should be provided to maintain the generator compartment temperatures below 104°F (40°C)	

SPECIFICATIONS - 5.5/5.0KW EDC GENERATOR

ENGINE SPECIFICATIONS

Engine Type	Diesel, four-cycle, three-cylinder, fresh water-cooled, vertical in-line overhead valve mechanism (9.2 Hp at 1800 rpm maximum).
Aspiration	Naturally aspirated
Governor	Electronic
Combustion Chamber	Swirl type
Bore & Stroke	2.76 x 2.76 inches (70 x 70 mm)
Piston Displacement	49.31 cubic inches (0.808 liters)
Firing Order	1 - 3 - 2
Direction of Rotation	Clockwise, when viewed from the front
Maximum Torque (at 1800 rpm)	27 ft-lb (3.4 kg-m)
Compression Ratio	23 : 1
Weight	373 lbs (169 kgs)
Fuel Consumption	
1800 rpm F/L	0.61 gph (2.3 lph)
1500 rpm F/L	0.54 gph (2.1 lph)
Inclination	Continuous 25° in all directions Temporary 30° (not to exceed 30 min.)

TUNE-UP SPECIFICATIONS

Compression Pressure (Limit of Difference Between Cylinders)	398 psi (28 kg/cm ²) at 280 rpm limit (47.2 psi (3.0 kg/cm ²))
Valve Timing	Intake Opens 19° BTDC Intake Closes 51° ABDC Exhaust Opens 51° BBDC Exhaust Closes 19° ATDC
Timing Spill	15° BTDC ± .5°
Valve Seat Angle	Intake 45° Exhaust 45°
Engine Speed	1800 rpm 60 Hertz 1500 rpm 50 Hertz
Valve Clearance (engine cold)	Intake and Exhaust 0.098 inches (0.25 mm)
Injector Pressure	1988 ± 142 psi (140 ± 10 kg/cm ²)

AC GENERATOR (SINGLE PHASE)

General - Single Phase	Brushless, four-pole, revolving field. Self-exciting capacitor saturated field excitation. Pre-lubricated, single-bearing design
Voltage - Single Phase	120 Volts - 60 Hertz 230 Volts - 50 Hertz
Voltage Regulation	±5% no load to full load
Frequency Regulation	.5 Hertz no load to full load
Rating (Volts/Amps AC)	60 Hertz (1800 rpm) 120 Volts 44.8 Amps 50 Hertz (1500 rpm) 230 Volts 21.7 Amps
Electromagnetic Interference level	Exceeds requirements for most marine radio telephones and standard televisions. Meets CE (Certified Europe) requirements.

ELECTRICAL SYSTEM

Starting Battery	12-Volt, (-) negative ground
Battery Capacity	800 - 1000 Cold Cranking Amps (CCA)
Starter	12-Volt, reduction
Starting Aid	Glow plugs, sheathed type
DC Cranking Current	150 - 175 Amps (engine cold)
DC Charging	Belt driven 50 amp alternator-internal regulator

FUEL SYSTEM

General	Open flow, self bleeding - self priming
Fuel	No. 2 diesel oil (cetane rating of 45 or higher)
Fuel Injection Pump	In-line plunger, Bosch type
Fuel Injection Timing (spill timing)	15° BTDC ± 5°
Nozzle	Throttle type
Fuel Filter	Cartridge
Air cleaner	Air intake silencing system
Air Flow (engine combustion)	31.2 cfm (0.5787 cmm)

COOLING SYSTEM

General	Fresh water-cooled block, thermostatically-controlled with heat exchanger.
Operating Temperature	170 - 190° F (77 - 88° C)
Fresh Water Pump	Centrifugal type, metal impeller, belt-driven
Raw Water Pump	Positive displacement, rubber impeller, mechanically-driven.
Raw Water Flow, at 1800 rpm	6.5 - 7.0 US gpm (24.6 - 26.5 lpm) (measured before discharging into exhaust elbow).
System Capacity (fresh water)	4 qts (3.79 liters)

LUBRICATION SYSTEM

General	Pressure fed system by geared pump.
Oil Filter	Full flow, paper element, spin-on type.
Sump Capacity (not including filter)	3.2 U.S. qts (3.03 liters).
Operating Oil Pressure (engine hot)	35 - 55 psi (2.5 - 3.8 kg/cm ²).
Oil Grade	API Specification CF or CG-4, SAE 30, 10W-30, 15W-40.

GENERATOR COOLING

Cooling	Cast Centrifugal blower, direct connected.
Air Requirements (60 Hertz @ 1800 rpm)	175 - 200 cfm (4.95 - 5.66 cmm)
NOTE: Increase air supply 15% for 50 Hertz operation @ 1500 rpm.	
Engine Combustion Air Requirements (60 Hertz @ 1800 rpm)	31.2 cfm (0.57 cmm)
NOTE: Forced ventilation should be provided to maintain the generator compartment temperatures below 104° F (40° C)	

GENERATOR INFORMATION

USE OF ELECTRIC MOTORS

The power required to start an electric motor is considerably more than is required to keep it running after it is started. Some motors require much more current to start them than others. Split-phase (AC) motors require more current to start, under similar circumstances, than other types. They are commonly used on easy-starting loads, such as washing machines, or where loads are applied after the motor is started, such as small power tools. Because they require 5 to 7 times as much current to start as to run, their use should be avoided, whenever possible, if the electric motor is to be driven by a small generator. Capacitor and repulsion-induction motors require from 2 to 4 times as much current to start as to run. The current required to start any motor varies with the load connected to it. An electric motor connected to an air compressor, for example, will require more current than a motor to which no load is connected.

In general, the current required to start 115-Volt motors connected to medium starting loads will be approximately as follows:

MOTOR SIZE (HP)	AMPS FOR RUNNING (AMPERES)	AMPS FOR STARTING (AMPERES)
1/6	3.2	6.4 to 22.4*
1/4	4.6	9.2 to 32.2*
1/3	5.2	10.4 to 72.8*
1/2	7.2	14.4 to 29.2*
3/4	10.2	20.4 to 40.8*
1	13	26 to 52

***NOTE:** In the above table the maximum Amps for Starting is more for some small motors than for larger ones. The reason for this is that the hardest starting types (split-phase) are not made in larger sizes.

Because the heavy surge of current needed for starting motors is required for only an instant, the generator will not be damaged if it can bring the motor up to speed in a few seconds. If difficulty is experienced in starting motors, turn off all other electrical loads and, if possible, reduce the load on the electric motor.

Required Operating Speed

Run the generator first with no load applied, then at half the generator's capacity, and finally loaded to its full capacity as indicated on the generator's data plate. The output voltage should be checked periodically to ensure proper operation of the generating plant and the appliances it supplies. If an AC voltmeter or ampere meter is not installed to monitor voltage and load, check it with a portable meter and amp probe.

NOTE: When the vessel in which the generator is installed contains AC equipment of 120 volts only, it is recommended that the generator's AC terminal block be configured to provide one 120 volt AC hot leg for the vessel's distribution panel. This will ensure good motor starting response from the generator.

Generator Frequency Adjustment

Frequency is a direct result of engine/generator speed, as indicated by the following:

- When the generator is run at 1800 RPM, the AC voltage output frequency is 60 Hertz.
- When the generator is run at 1500 RPM, the AC voltage output frequency is 50 Hertz.

Therefore, to change the generator's frequency, the generator's drive engine's speed must be changed. A reconfiguration of the AC output connections at the generator is also necessary.

Generator Maintenance

- Maintaining reasonable cleanliness is important. Connections of terminal boards and rectifiers may become corroded, and insulation surfaces may start conducting if salts, dust, engine exhaust, carbon, etc. are allowed to build up. Clogged ventilation openings may cause excessive heating and reduced life of windings.
- For unusually severe conditions, thin rust-inhibiting petroleum-base coatings, should be sprayed or brushed over all surfaces to reduce rusting and corrosion. Typical materials suggested are Daubert Chemical Co. "Non-Rust AC-410" and Ashland "Tectyle 506" or equivalent.
- In addition to periodic cleaning, the generator should be inspected for (a) tightness of all connections, (b) evidence of overheated terminals and (c) loose or damaged wires.
- The drive discs on single bearing generators should be checked periodically if possible for tightness of screws and for any evidence of incipient cracking failure. Discs should not be allowed to become rusty because rust may accelerate cracking. The bolts which fasten the drive disc to the generator shaft must be hardened steel SAE grade 8, identified by 6 radial marks, one at each of the 6 corners of the head.
- The rear armature bearing is lubricated and sealed; no maintenance is required. However, if the bearing becomes noisy or rough-sounding, have it replaced.
- Examine bearing at periodic intervals. No side movement of shaft should be detected when force is applied. If side motion is detectable, bearings are wearing or wear on shaft of bearing socket outside bearing has occurred. Repair must be made quickly or major components will rub and cause major damage to generator.

7.6/5.7KW EDT GENERATOR SINGLE PHASE

DESCRIPTION

This generator is a four-pole, brushless, self-excited generator which requires only the driving force of the engine to produce AC output. The copper and laminated iron in the exciter stator are responsible for the self-exciting feature of this generator. The magnetic field produced causes an AC voltage to be induced into the related exciter rotor windings during rotation. Diodes located in the exciter rotor rectify this voltage to DC and supply it to the windings of the rotating field. This creates an electromagnetic field which rotates through the windings of the main stator, inducing an AC voltage which is supplied to a load. A step down transformer is connected in parallel to the AC output of the main stator. An AC voltage is produced in the auxiliary windings of the transformer and the main stator and is, in turn, supplied to a full-wave bridge rectifier. The rectifier produces a DC voltage to further excite the exciter stator windings, enabling the generator to produce a rated AC output.

Circuit Breaker

A circuit breaker is installed on all WESTERBEKE generators. This circuit breaker will automatically disconnect generator power in case of an electrical overload. The circuit breaker can be manually shut off when servicing the generator to ensure no AC power is coming from the generator to the vessel.

NOTE: This circuit breaker is available as a WESTERBEKE add-on kit for earlier model generations; contact your WESTERBEKE dealer.

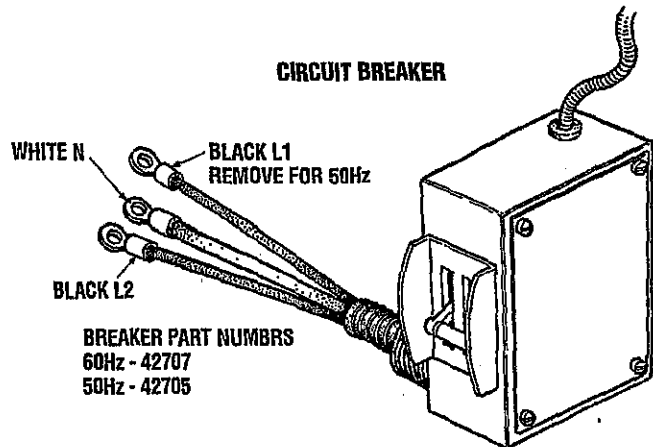

INTERNAL WIRING FOR 12 STUD BT GENERATOR

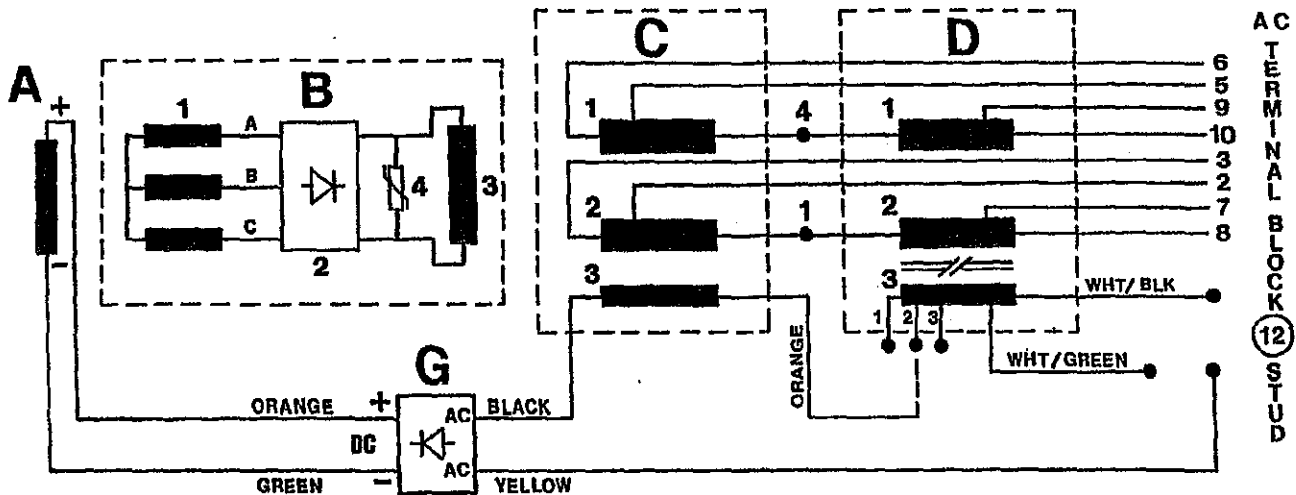

A. EXCITER STATOR WINDING
A - 1 Exciter Stator Windings

B. EXCITER ROTOR and FIELD
1. Auxiliary Windings (A - B - C)
2. Diodes (6)
3. Rotating Field Windings
4. Pozi Resistor

C. MAIN STATOR
1. Main Stator Windings
2. Main Stator Windings
3. Main Stator Auxiliary Windings

D. COMPOUND TRANSFORMER
1. Compound Transformer Windings
2. Compound Transformer Windings
3. Compound Transformer Auxiliary Windings

Resistance readings and voltage checks can be accessed easily for the components in the exciter circuit A, G, C-3 and D-3 by locating the color coded wires at the connection points shown on the above schematic. When checking winding resistance values be sure to lift both of the component's electrical connections.

G. BRIDGE RECTIFIER

7.6/5.7KW EDT GENERATOR TROUBLESHOOTING

The following troubleshooting chart is designed to give insight into problems which may be encountered with the BT brushless generators operating on compound transformer regulation. Owing to the simplicity of the equipment and controls, troubleshooting is relatively easy, once the relationship between cause and effect is understood. Most potential problems are covered in the text of this guide; however should an omission or an error be found, we would greatly appreciate your notifying us of it.

Keep in mind that a basic fundamental knowledge of electricity is required for this troubleshooting, and always remember that lethal voltages are present in the circuitry; therefore, extreme caution is essential when troubleshooting a generator.

Only a few basic tools are necessary for diagnosis and repair. These are hand tools; an amp probe and a quality volt-ohmmeter capable of reading less than one ohm due to the precision required in reading component winding resistances.

Before attempting any repairs, get a clear explanation of the problem as possible, preferably from an individual witnessing the problem. In some cases, this may bring to light a problem which is related to the method of operation rather than equipment fault. Bring basic repair tools with you on the initial trip to the problem equipment, such as: diodes and bridge rectifier, so that if the problem should be found in one of these easily replaceable parts, the problem can be remedied early and efficiently.

REFER TO THE INTERNAL WIRING DIAGRAMS WHEN PERFORMING THE FOLLOWING TESTS.

TROUBLESHOOT THE COMPONENTS IN THE FOLLOWING ORDER:

1. LOW VOLTAGE 60-100 VOLTS AC COMPONENT CHECKS:

B ROTOR COMPONENTS

B2. EXCITER ROTOR DIODES

B3. ROTOR FIELD WINDING

B1. EXCITER ROTOR WINDING(S) a,b,c.

A 1-1+2 EXCITER STATOR WINDING(S).

2. NO AC VOLTAGE OUTPUT MAIN STATOR, ROTOR COMPONENTS, TRANSFORMER COMPONENT CHECKS:

C 1+2 MAIN STATOR WINDING

B 4 POSI RESISTOR

B 2 DIODES (4-6 OPEN/SHORTED)

D 1+2 COMPOUND TRANSFORMER WINDING

B 3 ROTOR FIELD WINDING

3. RESIDUAL VOLTAGE EXCITER CIRCUIT FAULTY COMPONENT CHECKS:

A 1-1+2 EXCITER STATOR WINDING(S)

G BRIDGE RECTIFIER

D 3 TRANSFORMER AUX. WINDING

C 3 MAIN STATOR AUX. WINDING

7.6/5.7KW EDT GENERATOR SINGLE PHASE

NO-LOAD VOLTAGE ADJUSTMENT

1. Voltage adjustment is made with the generator regulation being governed by the compound transformer.
2. Operate the generator, apply a moderate load momentarily and remove it. Note the voltage output from the generator's 120 volt leg(S) (230 volt 50 hertz). The no-load voltage should be between 121 - 124 volts at 61.5 - 62 hertz (234 - 238 volts at 51.5 - 52 hertz).

NOTE: The no-load voltage should be adjusted to the voltage produced by the generator once started and a momentary load should be applied to excite the transformer and then removed. The voltage produced by the generator after this momentary load is removed is no-load voltage.

3. To raise or lower the voltage, shims of varying thickness (non-conductive material) are placed or removed from under the steel laminated bar on top of the compound transformer. The material used for shimming should not soften at temperatures in the 176° F (80° C) range. A small reduction in no-load voltage (1 to 3 volts) can sometimes be accomplished by gently tapping the top of the laminated steel bar to reduce the gap between the existing shims and the transformer core.

Generator Frequency

1. Frequency is a direct result of engine/generator speed:
1800 rpm = 60 hertz; 1500 rpm = 50 hertz.
2. To change generator frequency follow the steps below.
 - a. Configure the AC terminal block for the desired voltage frequency as shown below. Ensure that the case ground wire is connected to the correct terminal block neutral ground stud.

NOTE: The white/green ground wire may be removed in those installations where the AC circuit has a separate neutral and ground circuit. This will prevent the unit from being a ground source in the vessel.

- b. Start the engine, monitor voltage and adjust engine no-load speed. Adjust the throttle arm or the throttle stop screw to produce engine speed desired.
 - 60 hertz: no-load speed, 61.5 - 62.0 hertz.
 - 50 hertz: no-load speed, 51.5 - 52.0 hertz.

- c. After the no-load hertz adjustment is made, the no-load voltage may need to be readjusted. In most cases, if the generator was producing the correct no-load voltage at the previous hertz setting, it would be correct at the changed hertz setting.

In the event it needs adjustment, adjust the shim thickness under the laminated steel bar of the transformer.

- 60 hertz: no-load voltage, 121 - 124 volts.
- 50 hertz: no-load voltage, 234 - 238 volts.

- d. Load the generator to the rated amperage output corresponding to the hertz speed of the generator.

Rated Loaded Speed

60 hertz: loaded speed, 59.5 - 60.0 hertz

50 hertz: loaded speed, 49.5 - 50.0 hertz

Maximum voltage drop acceptable at full rated output (amps)

60 hertz: 108 - 110 volts

50 hertz: 215 - 220 volts

Should the voltage drop below the proper rate, loaded excitation can be increased to raise this voltage by repositioning the connection on the Voltage Connection Terminal.

TERMINAL BLOCK WIRING CONNECTIONS

Winding Connections Needed To Obtain The Proper Voltage and Frequency

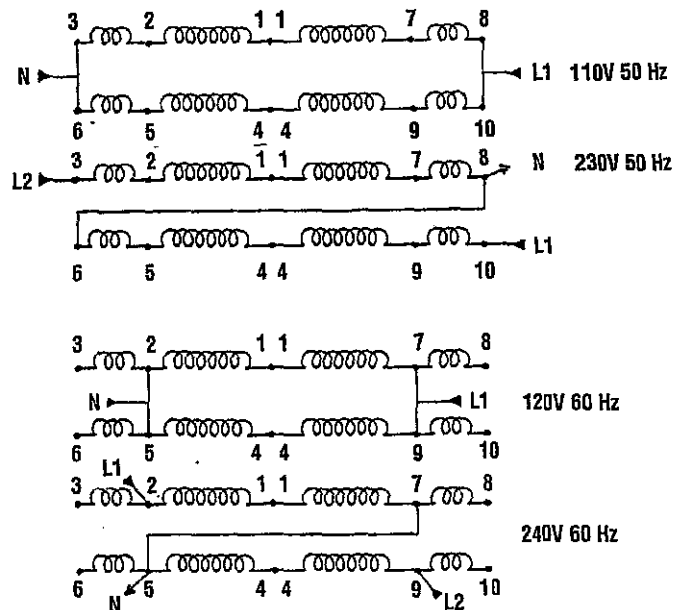

The frame ground wire must be removed when changing from 115 volts and 110/220 volts 50 hertz to 230 volts 50 hertz. From making connections to the AC terminal block, use terminal ends for 1/4 inch studs that will accept multi-strand copper wire sized for the amperage rating from the hot lead connection. The frame ground wire is white or white with a green strip. It connects between the neutral stud and the generator frame.

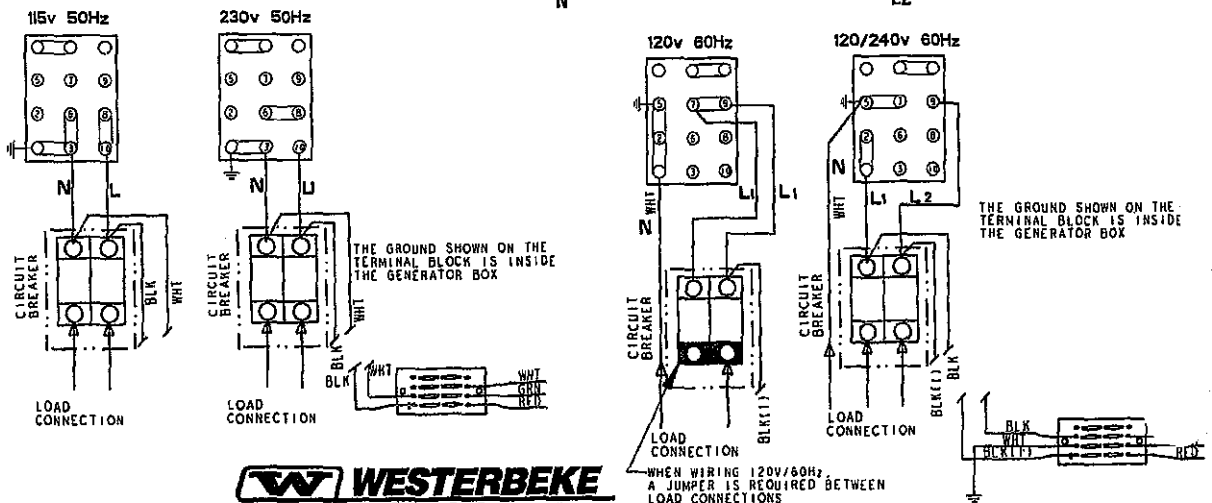

WESTERBEKE
Engines & Generators

7.6/5.7KW EDT GENERATOR SINGLE PHASE

INTERNAL WIRING FOR 12 STUD BT GENERATOR

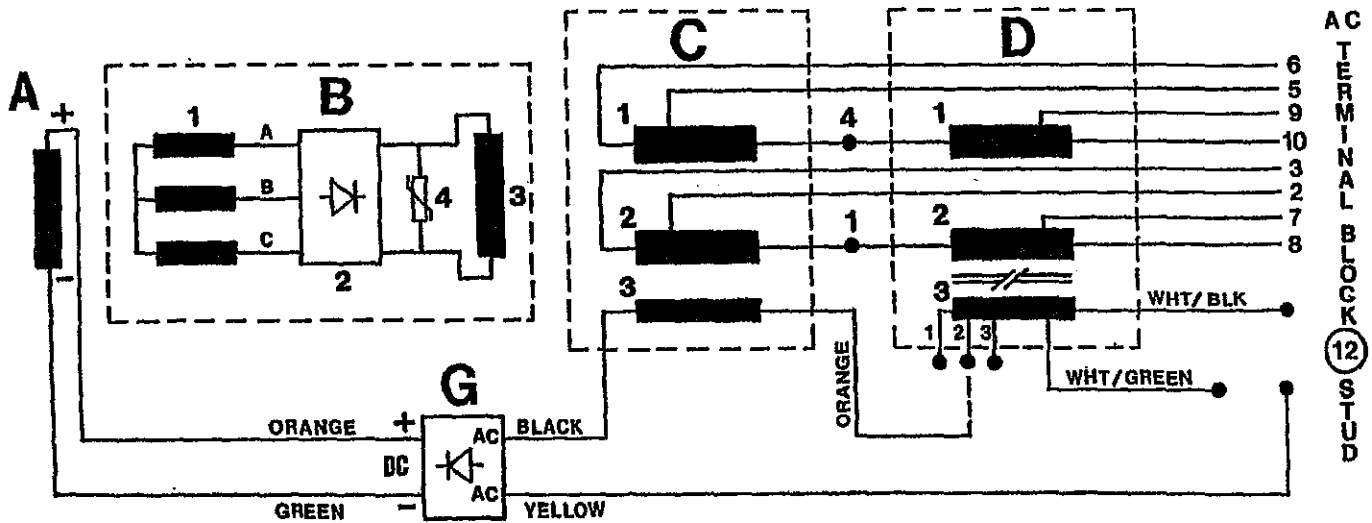

RESIDUAL VOLTAGE CHECK

1. Residual Voltage 18 - 22 volts AC.

NOTE: The amount of no-load voltage produced by the generator can be an indicator of where in the generator the problem/fault may lie.

This voltage is the AC voltage produced by the generator from magnetism in the exciter stator field. This voltage is measured between the AC neutral and hot leg(s) with no-load on the generator running at its hertz.

The presence of residual voltage is an indication that the following generator components are OK:

1. Exciter Rotor (B-1 a, b, & c) & (B-2)
2. Rotating Field (B-3)
3. Main Stator (C-1 & C-2)
4. Compound Transformer (D-1 & D-2)

The fault lies in one or more of the following components in the exciter circuit:

- A. Exciter Stator (A-1)
- B. Bridge Rectifier (G)
- C. Main Stator Auxiliary Windings (C-3)
- D. Compound Transformer Auxiliary Winding (D-3)

2. Twelve (12) volts DC excitation of the exciter stator windings should cause the generator to produce between 125 - 135 volts AC between each hot lead and the neutral. (Twelve volts DC is applied between the lifted (+) and (-) leads of the bridge rectifier, + to + and - to -.) Correct voltage produced with twelve volts DC excitation indicates the fault is in one or more of the above listed components B, D or E. If the generator does not produce 125 - 135 volts AC, then include A and C.
3. The absence of any voltage from the generator indicates a fault with the main stator windings C-1 and C-2 and/or the compound transformer windings D-1 and D-2. Other failed components that can produce this same no-voltage output are the posi-resistor in the exciter rotor and four or more failed diodes in the exciter rotor.

- a. Apply 12 volt DC excitation to the exciter stator windings as explained in paragraph 2. A fault in the main stator and/or compound transformer windings such as a short will cause the generator engine to load down and the shorted windings to eventually produce smoke as the excitation is continued.
4. Voltage output greater than residual and less than the rated output indicates a fault in the exciter rotor/field B-1, B-2, B-3. Excitation of the generator as explained in paragraph 2 should produce a partial rise in voltage output and, when removed, the voltage will return to the original low output.

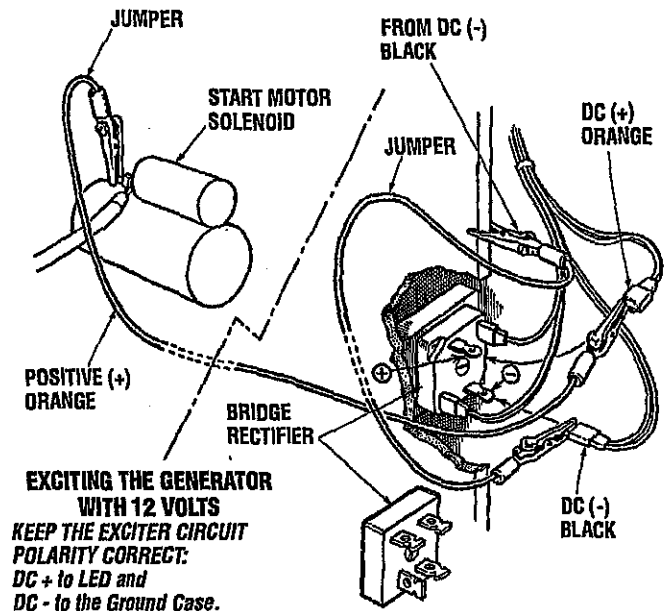

NOTE: Current model bridge rectifiers are configured differently, but + and - are still located at the corners.

7.6/5.7KW EDT GENERATOR SINGLE PHASE

BRIDGE RECTIFIER

The bridge rectifier is supplied AC voltage from the auxiliary windings in the generator stator (C-3) and the compound transformer (D-3). The AC voltage measured across the AC terminals of the rectifier during engine operation is as follows:

120 Volts N/L F/L	120/240 Volts N/L F/L
17-44 volts AC	17-44 volts AC

Diodes in the rectifier convert this AC voltage to DC and supply it to the windings of the exciter stator to induce a field through which the exciter rotor revolves. The DC voltage measured across the (+) and (-) terminals of the bridge rectifier during engine operation is as follows:

120 Volts N/L F/L	120/240 Volts N/L F/L
8 - 17 volts DC	8 - 17 volts DC

Failure of the bridge rectifier will result in a weak field being produced by the exciter stator windings. A weak field is present, due to the magnetism in the exciter stator, which will cause the generator to produce residual voltage.

BRIDGE RECTIFIER

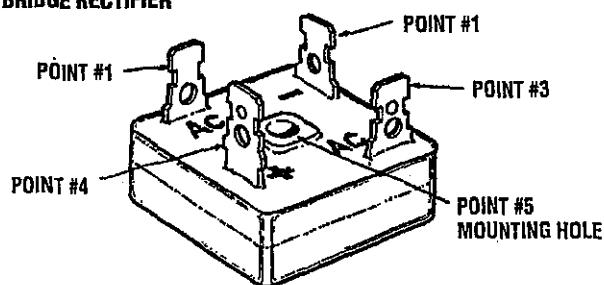

Testing The Bridge Rectifier For Faults With An Ohmmeter

(Meter used: *Simpson 260*)

1. Set the ohmmeter scale on RX1 (+ DC) and set the needle to zero.
2. Connect the positive (+) lead from the ohmmeter to point #4. Taking the ohmmeter's negative (-) lead, momentarily contact points #1, #2, #3, and #5. The ohmmeter should register no deflection for any of the points touched.
3. Remove the positive (+) lead from point #4 and connect the negative (-) lead to point #4 and, with the positive (+) lead, momentarily touch points #1, #2, and #3. The ohmmeter's needle should deflect when each point is touched, showing a passage of meter voltage through the diodes in the rectifier.
4. Leaving the negative (-) ohmmeter lead on point #4, touch point #5 with the positive (+) lead. No deflection of the needle should occur.
5. Place the positive (+) lead of the ohmmeter on point #1 and the negative (-) lead on point #3. The ohmmeter should not register any deflection of the needle (no deflection indicates infinite resistance). Reverse these connections and the ohmmeter should again register no deflection.

If the rectifier fails any of the previous tests (1 -4) it is defective and should be replaced.

NOTE: Different style/model meters may produce opposite results from the above tests.

7.6/5.7KW EDT GENERATOR SINGLE PHASE

EXCITER ROTOR/FIELD

Auxiliary windings group a, b and c. Locate the three terminal points on the exciter rotor for these auxiliary winding groups. Position the exciter rotor as shown in the illustration and count off the porcelain knobs from the 12 o'clock point either left or right to locate terminal points a, b and c. Measure the resistance value between the pairs of terminal points A & B, B & C, and C & A. There is no need to unsolder these connections unless a faulty reading appears. If this occurs, unsolder and verify the winding fault. There should be no continuity found between any of the three terminal points and the rotor shaft/case ground.

Auxiliary Windings 1.0 - 1.2 Ohms

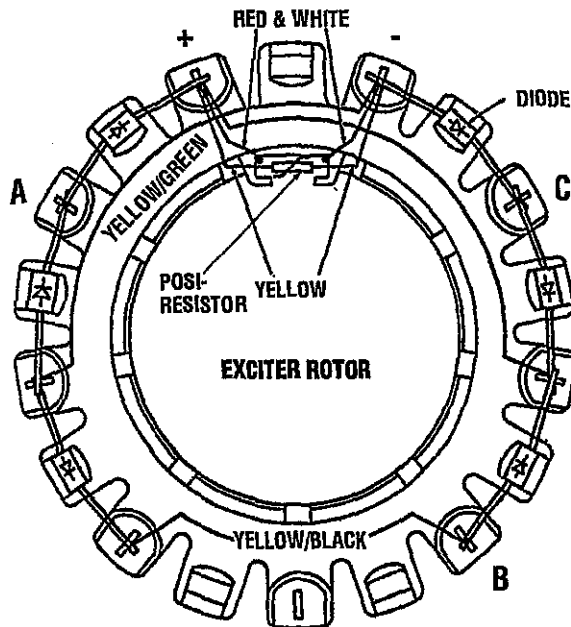

Rotating Field Windings. Refer to the illustration above of the exciter rotor. The field winding connections are noted as the (+) and (-) connections of the red & white striped wires. Measure the resistance value with your ohmmeter between these two connection points. These connections need not be unsoldered unless a faulty reading appears. If this occurs unsolder the connection and verify the resistance reading. With these connections lifted, there should be no continuity to the rotor shaft. This would indicate a short to ground with these field windings.

Diodes. Six diodes are mounted on the exciter rotor; they rectify the AC voltage produced by the three groups of auxiliary windings to DC voltages and supply this DC voltage to the rotating field windings.

RESISTANCE VALUE

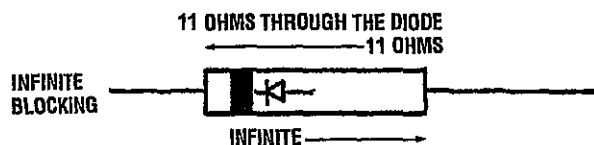

The diodes can be easily checked in place with the use of a common automotive 12-volt high beam headlight bulb, some jumper leads and the generator's 12 volt starting battery.

A short or an open in a diode can easily be found with the above without having to unsolder and isolate each diode to check it with an ohmmeter.

NOTE: Attempting to check diodes in place with an ohmmeter will give erroneous readings on the diodes due to the auxiliary winding's connections.

When leads are put across the diode, as illustrated, voltage passes through the diode allowing the headlight to glow brightly.

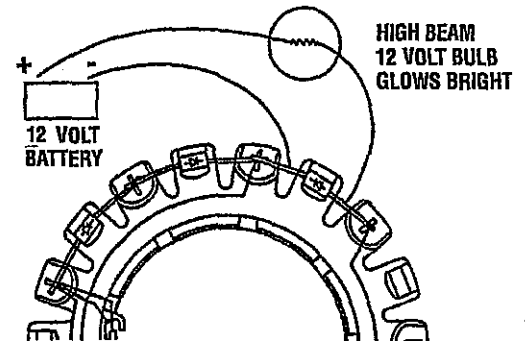

Reverse the leads across the diode. The diode should block voltage passing through it, and the headlight should not glow, or it may glow faintly.

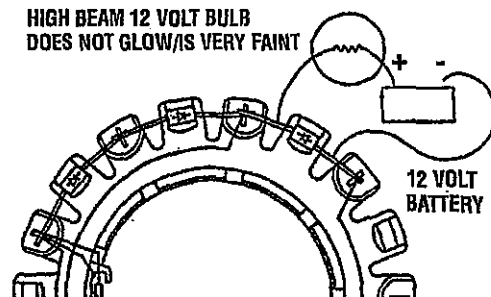

- Should the bulb not glow with leads connected in both directions, the diode is open internally.
- Should the bulb glow with leads connected in both directions, the diode is shorted internally.

In both a and b above, the diode should be replaced. Check the resistance values of the rotating field windings and the integrity of the resistors connected between the field windings.

Rotating Field Windings 7.0-8.0 ohm. (Reading taken between the two red & white wires connected to the (+) and (-) terminals of the exciter rotor as shown in the illustration.)

Posi-resistor. (Infinite readings between both yellow leads lifted from the (+) and (-) terminals on the exciter rotor.) A shorted posi-resistor will destroy the rotating field and cause the AC output voltage to drop to zero.

7.6/5.7KW EDT GENERATOR SINGLE PHASE

MEASURING RESISTANCE

Main Stator Windings

- Group #1.** The resistance value is measured between the lifted lead #4 from the insulated terminal below the transformer and lead #6 lifted from the AC terminal block. In order to totally isolate the stator windings of group #1, lead #5 should be lifted from the terminal block.
 - Group #2.** The resistance value is measured between the lifted lead #1 from the insulated terminal below the transformer and lead #3 lifted from the AC terminal block. In order to totally isolate the stator windings of group #2, lead #2 should be lifted from the terminal block.
- Main Stator Windings .20 - .22 Ohms
- Main Stator Auxiliary Windings** are measured between the double leads on the AC terminal of the bridge rectifier, unplugged from the rectifier and the double lead central prong connection of the regulator plug.
- Main Stator Auxiliary Windings 1.5 - 1.8 Ohms

NOTE: No continuity should be found between either of these winding groups or to the generator case.

Compound Transformer

Group 1 measured between Lead #10 at the AC terminal block and Lead #4 at the junction box. Lift both leads along with lead #9 at the terminal block.

Group 2 measured between Lead #8 at the AC terminal block and Lead #4 at the junction block. Lift both leads along with lead #7 at the terminal block.

Compound Transformer Windings 0.019 - 0.021 Ohms

A three connection voltage connection terminal was added to this circuit located just below the AC terminal block at the lower left. Isolate the three numbered #1, #2, and #3 red and white-striped wires coming onto each of the three terminals. Lift the black and white-striped leads and the green and white-striped leads off of their connections on the AC terminal block. Measure the resistance value between the #1 red lead lifted from the terminal strip and the black and white striped lead lifted from the AC terminal block.

Transformer Auxillary Windings 4.0 - 4.5 Ohms

VOLTAGE CONNECTION TERMINAL

The addition of the three connection terminal is for the increase or decrease of full-load voltage output. Should full-load voltage fall below 108 volts, selecting a higher number terminal strip lead to connect the lead (red or red and white) will supply a higher AC voltage to the exciter circuit during full-load conditions, bringing the output voltage of the generator up.

No-load voltage should be properly adjusted by shimming the compound transformer: 121 - 124 volts at 61.5 - 62.0 hertz. The above should not be used as a means of compensating for incorrectly adjusting the generator's no-load voltage.

NOTE: For engine speed/hertz adjustment, see *ENGINE ADJUSTMENTS* in this manual.

VOLTAGE CONNECTION TERMINAL

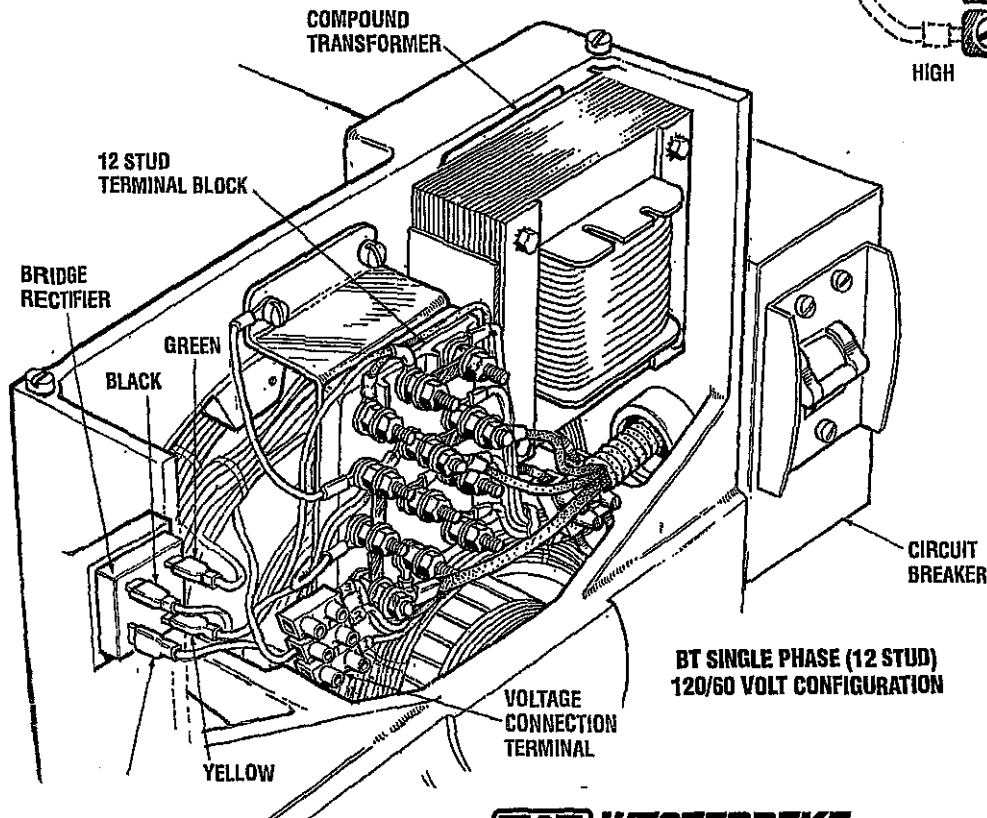
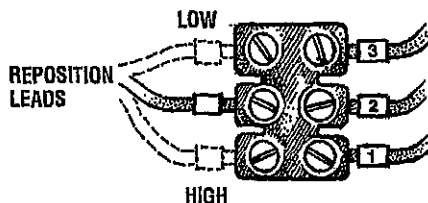

BT SINGLE PHASE (12 STUD)
120/60 VOLT CONFIGURATION

7.6/5.7KW EDT SHORE POWER TRANSFER SWITCH CONNECTIONS

If the installer connects shore power to the vessel's AC circuit, this must be done by means of the SHORE POWER/OFF/SHIPS GEN. Set the transfer switch shown in the diagrams to the OFF position. This switch prevents simultaneous connection of shore power to generator output.

⚠ CAUTION: Damage to the generator can result if utility shore power and generator output are connected at the same time. This type of generator damage is not covered under the warranty; it is the installer's responsibility to make sure all AC connections are correct.

⚠ CAUTION: Heavy motor leads should be shut off before switching shore power to generator power or vice-versa because voltage surges induced by switching with heavy AC loads on the vessel being operated may cause damage to the exciter circuit components in the generator.

Shore Power Connections (60 Hertz)

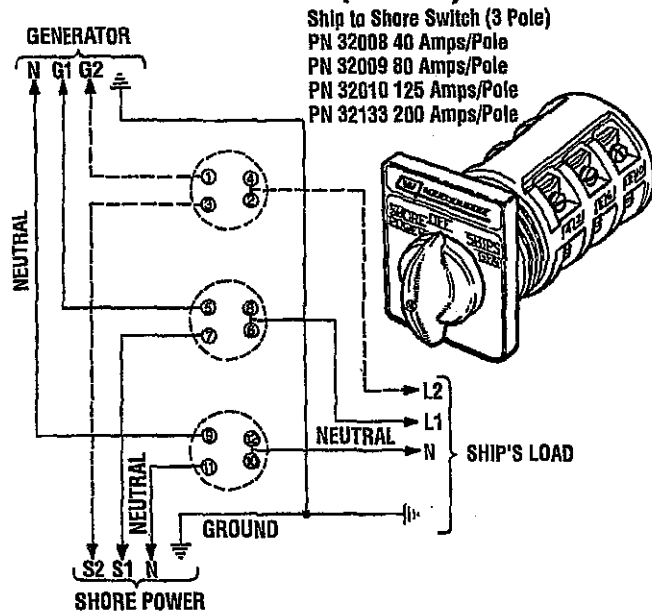

NOTE: Diagram shows connections for a two-wire, 120 volt system. For a three-wire system, use the dotted lines for the other hot leg.

230 Volt/50 Hertz Two Wire Configuration

Notice the repositioning of the white ground lead on the terminal block to the generator case.

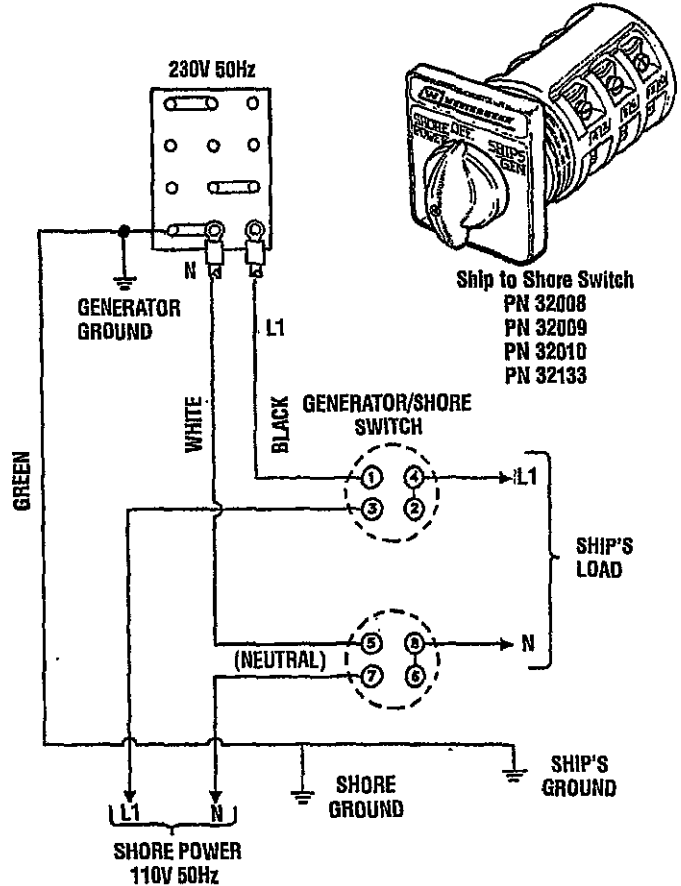

5.5/5.0 KW EDC GENERATOR SINGLE PHASE

DESCRIPTION

The BC generator is a brushless, self-excited generator which requires only the driving force of the engine to produce an AC output. The stator houses two sets of windings; the main stator windings and the exciter windings. When the generator is started, residual magnetism in the four rotating poles induces a current in the stator which then generates an even larger current in the exciter windings. This mutual build up of current in the four rotating poles and in the exciter windings quickly reaches the saturation point of the capacitor(s) and a regulated energy field is then maintained in the stator. At the same time, this regulated field produces a steady voltage in the stator windings which can then be drawn off the generator's AC terminals to operate AC equipment. The generator is a single-phase, reconnectable 120 volt AC two-wire or 120/240 volt AC three-wire, at 60 hertz; or 110 volt AC two-wire or 230 volt AC two-wire, at 50 hertz. Refer to the SPECIFICATIONS section of this manual for generator ratings. The generator's data plate gives the voltage, current and frequency rating of the generator. An AC wiring decal is affixed to the inside of the louvered cover at the generator end. A diagram of the various AC voltage connections is provided on the decal. An Integral Controller (IC) is mounted inside the generator and supplies a continuous DC charge to the generators starting battery when the generator is running. For more information see the INTEGRAL CONTROLLER DC CHARGER section in this manual.

Circuit Breaker

A circuit breaker is installed on all single phase WESTERBEKE generators. This circuit breaker will automatically disconnect generator power in case of an electrical overload. The circuit breaker can be manually shut off when servicing the generator to ensure that no power is coming into the generator.

NOTE: This circuit breaker is available as a WESTERBEKE add-on kit for earlier model generators; contact your WESTERBEKE dealer.

BREAKER PART NUMBERS
 60 Hz - 42705
 50 Hz - 42705

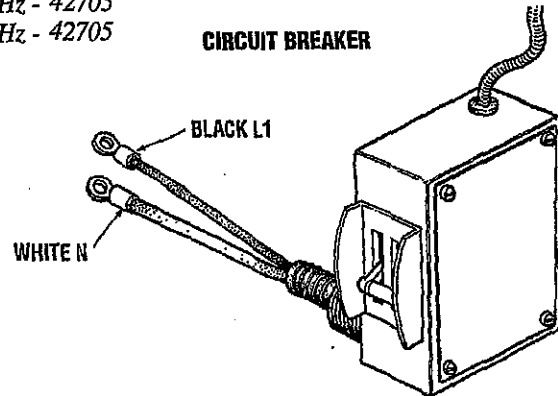

GENERATOR INTERNAL WIRING SCHEMATIC WITH DC BATTERY CHARGING CIRCUIT

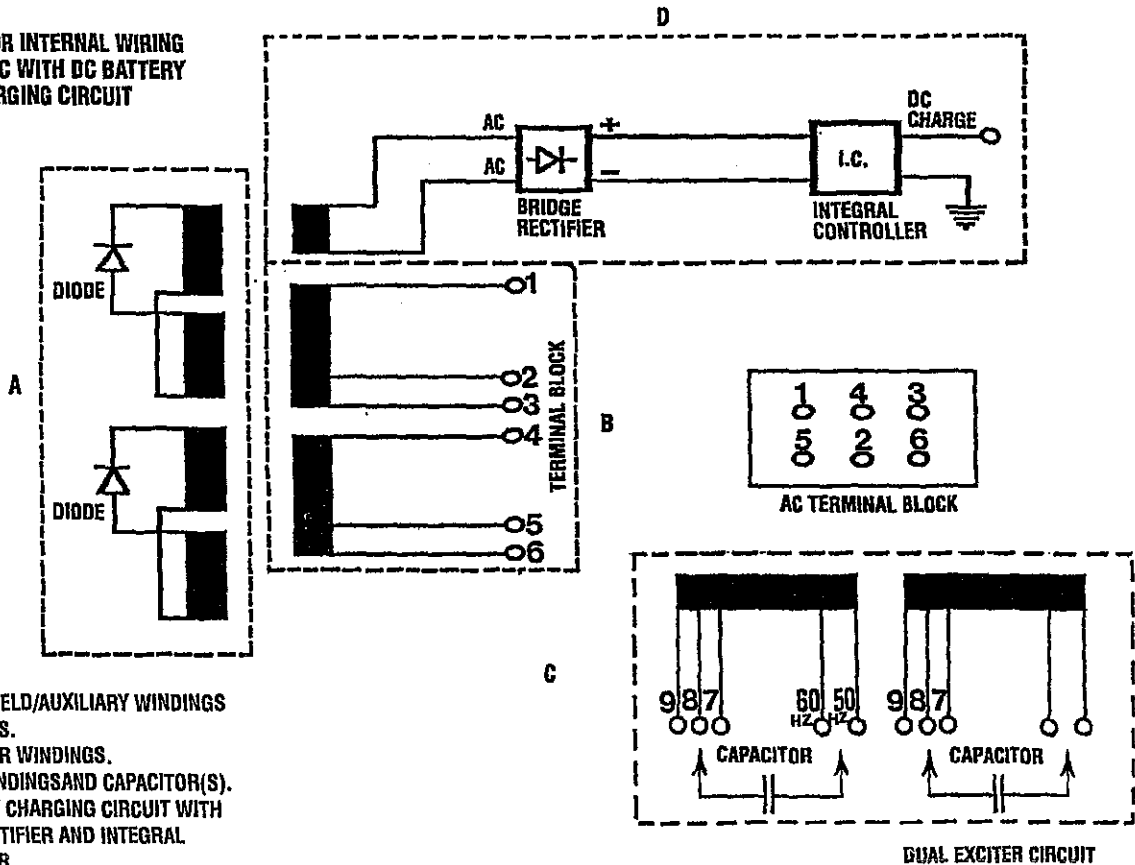

- A. ROTATING FIELD/AUXILIARY WINDINGS WITH DIODES.
- B. MAIN STATOR WINDINGS.
- C. EXCITER WINDINGS AND CAPACITOR(S).
- D. DC BATTERY CHARGING CIRCUIT WITH BRIDGE RECTIFIER AND INTEGRAL CONTROLLER.

5.5/5.0KW EDC GENERATOR TROUBLESHOOTING

The following troubleshooting chart is designed to give insight into problems which may be encountered with the single and dual capacitor BC brushless generators. Owing to the simplicity of the equipment and controls, troubleshooting is relatively easy, once the relationship between cause and effect is understood.

Keep in mind that a basic fundamental knowledge of electricity is required for this troubleshooting, and always remember that lethal voltages are present in the circuitry; therefore, extreme caution is essential when troubleshooting a generator.

Only a few basic tools are necessary for diagnosis and repair. These are hand tools: an amp probe and a quality volt-ohm-meter capable of reading less than one ohm due to the precision required in reading component winding resistances.

Before attempting any repairs, get a clear explanation of the problem as possible, preferably from an individual witnessing the problem. In some cases, this may bring to light a problem which is related to the method of operation rather than equipment fault.

Bring basic repair tools with you on the initial trip to the problem equipment, such as: diodes and bridge rectifier, so that if the problem should be found in one of these easily replaceable parts, the problem can be remedied early and efficiently.

Problem	Probable Cause	Verification/Remedy
No AC Output	<ol style="list-style-type: none"> 1. Shorted stator 2. Open stator 3. Shorter diodes (two) 	<ol style="list-style-type: none"> 1. Check stator windings 2. Check stator windings 3. Check diodes on rotor
Residual Voltage 4 - 6 VAC (Hot N) at No-load	<ol style="list-style-type: none"> 1. Faulty capacitor 2. Open exciter 3. Shorted exciter 4. Electrical connections faulty 	<ol style="list-style-type: none"> 1. Check capacitor 2. Check exciter windings 3. Check exciter windings 4. Inspect/clean and tighten connections
High AC Output at No Load	<ol style="list-style-type: none"> 1. Incorrect voltage tap on capacitor 2. Incorrect capacitor 3. Incorrect hertz tap on capacitor 	<ol style="list-style-type: none"> 1. Correct connections 2. Verify capacitor rating 3. Connect correct Hz tap
Low AC Output 60-106V	<ol style="list-style-type: none"> 1. Faulty rotor winding 2. Faulty diode 3. Faulty capacitor 	<ol style="list-style-type: none"> 1. Check rotor windings 2. Check diodes 3. Verify capacitor rating
Voltage Drop Under Load (or at no-load)	<ol style="list-style-type: none"> 1. Faulty diode 2. Faulty capacitor 	<ol style="list-style-type: none"> 1. Check/replace diode 2. Verify capacitor ratings/replace
No Battery Charge/Low Battery Charge	<ol style="list-style-type: none"> 1. Faulty bridge rectifier 2. Faulty Integral controller 3. Blown fuse 4. Faulty winding 	<ol style="list-style-type: none"> 1. Check rectifier diodes 2. Troubleshoot controller 3. Inspect/replace 30 amp fuse 4. Check charge circuit windings
Unstable Voltage	<ol style="list-style-type: none"> 1. Electrical connections are faulty/loose 	<ol style="list-style-type: none"> 1. Check/clear/tighten electrical connections
Noisy Operation	<ol style="list-style-type: none"> 1. Faulty support bearing 2. Generator rotor connection to engine is loose 	<ol style="list-style-type: none"> 1. Inspect rear rotor carrier bearing 2. Inspect security of rotor to flywheel

5.5/5.0KW EDC GENERATOR SINGLE PHASE

DUAL EXCITER NO-LOAD VOLTAGE ADJUSTMENT

These generators have dual Hertz and no-load voltage adjustment connectors at each capacitor. There are five connectors available for each capacitor. Two connectors are for Hertz selection, 60 Hertz or 50 Hertz, and three connectors, #7, #8, and #9, are for no-load voltage adjustment.

When making Hertz change or no-load voltage adjustments proceed as follows:

1. Shut the generator down.
2. Select the appropriate Hertz connection to plug into each capacitor #60, 60 Hertz, 1800 RPM or 50, #50 Hertz, 1500 RPM. The three other connectors at each capacitor, #7, #8, and #9, will have an effect on the no-load voltage produced by the generator. One connector from each group can be plugged into each capacitor. No-load voltage will increase or decrease approximately 4 - 6 AC volts between connectors used in any pair combination to achieve the prescribed no-load voltage as illustrated below.

NOTE: When changing Hertz produced by the generator, an engine speed adjustment at the throttle arm linkage must be made. The AC output connections on the terminal blocks must be selected for the voltage and Hertz to be produced. The Hertz plug connection at the capacitor must be changed for 50 Hertz (#5) or 60 Hertz (#6). The frame ground wire must be moved when changing from 115 volts, 50 Hertz to 230 volts, 50 Hertz.

⚠ WARNING: Capacitors must be discharged before handling as they store electricity and can pack a potentially lethal charge even when disconnected from their power source.

NOTE: Simply cross the capacitor's two terminals with an insulated (plastic handle) screwdriver. This will discharge any excess electricity.

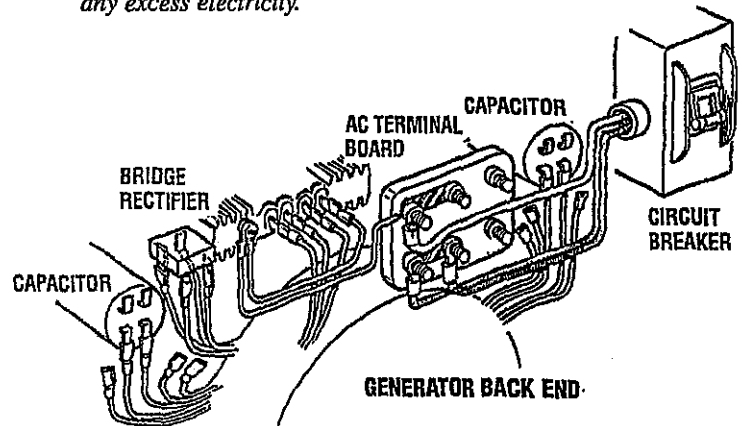
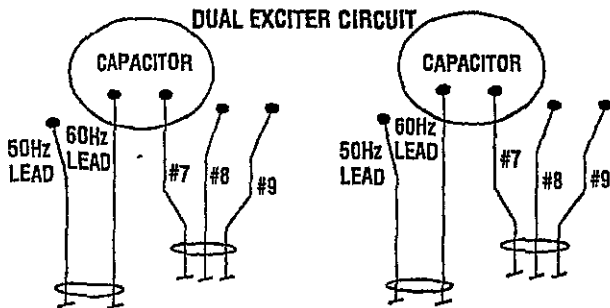

5.5/5.0 KW EDC GENERATOR SINGLE PHASE

SINGLE EXCITER NO-LOAD VOLTAGE ADJUSTMENT

1. Remove the louvered metal plate, at the back of the generator, covering the AC terminal connections and the capacitor(s).
2. Start the generator and allow it to run for approximately five minutes so the engine can warm up. Make sure the generator is operating without any equipment drawing AC current from the generator (that is, shut off all electrical appliances). Make sure the engine's speed (Hertz) is correct. Adjust the fuel throttle/speed linkage as needed to obtain the correct engine speed before proceeding.
3. Referring to the AC load connections diagram below, check the generator's no-load voltage by measuring the voltage across the neutral lead and the hot lead with a volt meter. Make sure you record this reading. The generator's no-load voltage is 115 - 124 volts at 60.5 - 61.5 Hertz. If the voltage output is higher or lower than specified, proceed.

⚠ WARNING: Do not attempt to make a no-load voltage adjustment while the generator is operating. The capacitor can produce a 400-500 volt charge. Touching any wiring can produce a severe electrical shock. In addition, attempting to make a no-load voltage adjustment while the generator is operating could cause your fingers to be caught in the generator's rotor.

4. Shut off the generator. Make sure the correct Hertz lead (60 Hertz #6, or 50 Hertz #5) is plugged into the capacitor(s).
5. There are three plugs grouped for the right capacitor terminal, #7, #8, and #9. If the generator's no-load voltage is low, then disconnect the lower numbered plug and connect the plug with the next higher number. If the generator's no-load voltage is high, then disconnect the higher numbered plug and connect the plug with the next lower number. Note that the plug presently connected to this terminal may be any one of the three plugs available.
6. If the generator's no-load voltage cannot be adjusted because the voltage needs to be increased and the highest numbered plug is already connected to the right terminal, or the voltage needs to be lowered and the lowest numbered plug is already connected, then adjust the no-load speed and check the capacitor ratings.

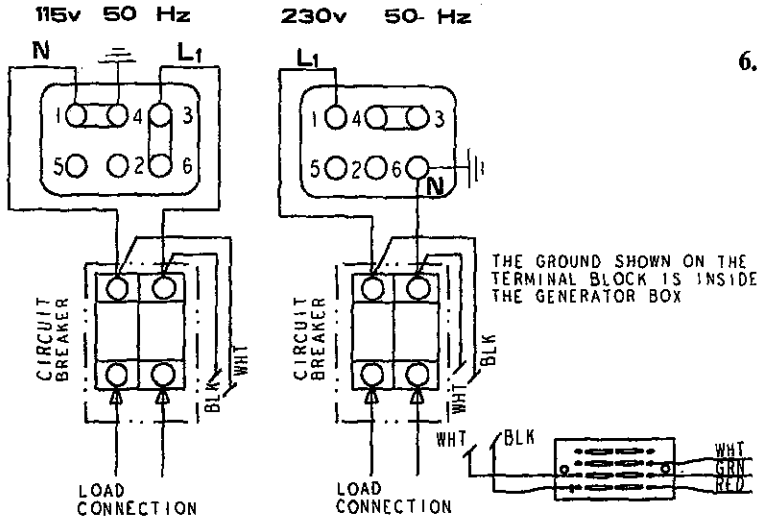

⚠ WARNING: Make certain the insulating covers on the unused leads are in place and are NOT in contact with each other or in contact with the generator's housing.

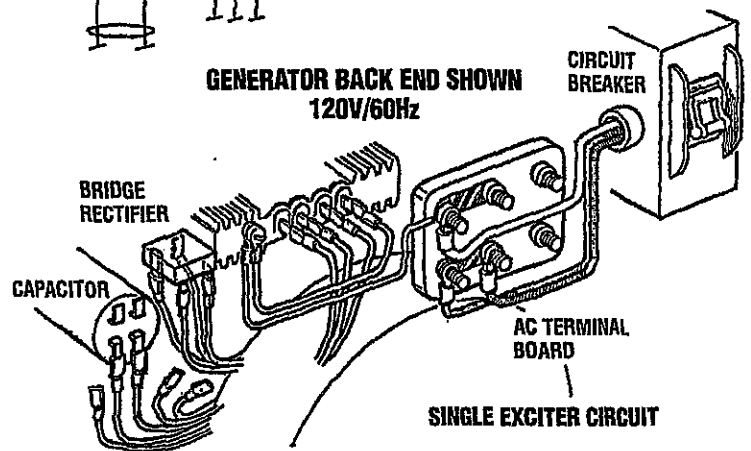
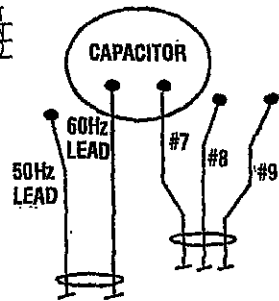
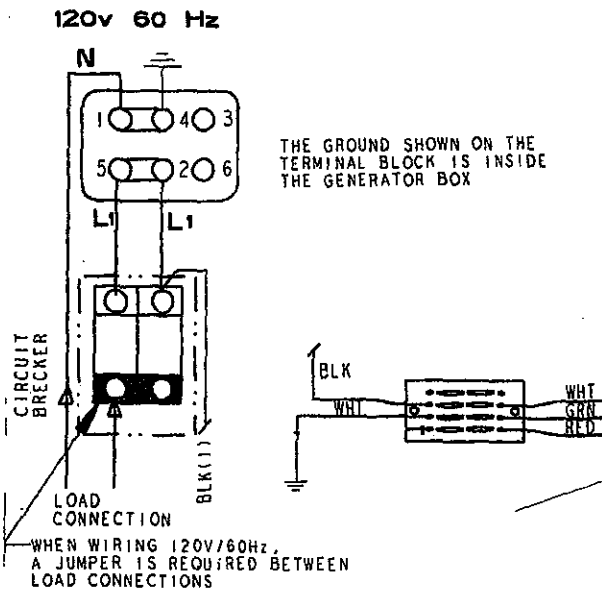

5.5/5.0KW EDC GENERATOR SINGLE PHASE

INTEGRAL CONTROLLER (I.C.)

The Integral Controller (I.C.) is an encapsulated, solid-state unit that supplies a DC charging voltage to the generator's starting battery while the generator is opening.

Charging Voltage: 13.0 - 14.0 volts DC
Charging Amperage: 0 - 10- amps DC

A separate group of stator windings supplies AC voltage to a bridge rectifier which converts the AC current to supply the I.C. unit. The I.C. unit senses the needs of the starting battery and supplies a DC charge when one is needed. If you suspect that the I.C. unit is faulty (that is, if the battery's charge is low), check the charging circuit and its components as described in the following steps. Check all connections for cleanliness and tightness including the ground before replacing the I.C. unit.

NOTE: When the generator is first started, the I.C. unit will produce a low charging rate. This charging rate will rise as the generator is operated.

The Integral Controller is mounted inside the generator housing in the 12:00 position. There is a voltage output adjustment on the controller that will allow a DC voltage output adjustment of ± 2 volts.

NOTE: New four wire controllers eliminate the ballast resistor circuit since the ballast resistor's function is now handled internally. Whenever replacing an early style controller with the newer four wire model, remove the ballast resistor and its wiring.

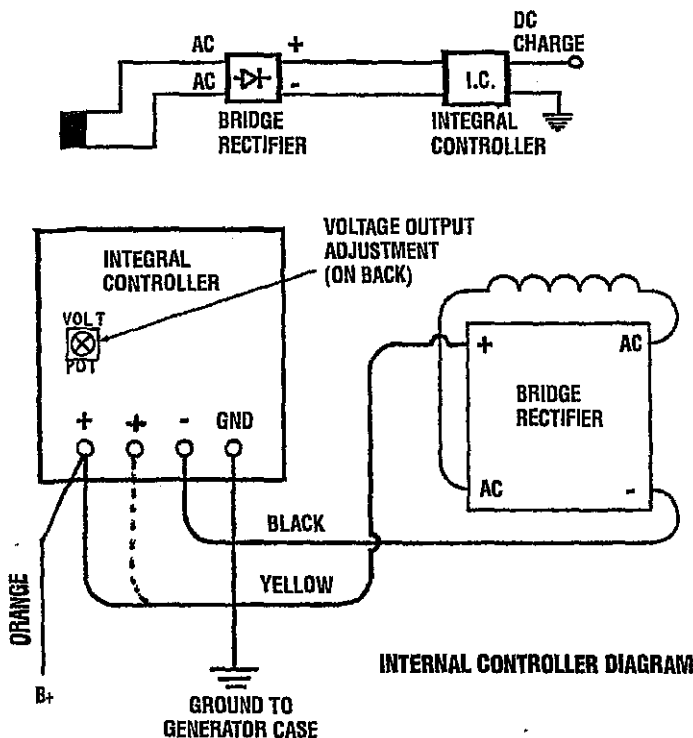

NOTE: Earlier model controllers had white/green (-) negative and white/black ground connections that are interchangeable.

Testing the Battery Charging Circuit

1. Bridge Rectifier

Normal AC voltage running to the rectifier (while the engine is operating at 1800 rpm) is measured across the two AC connections on the bridge rectifier. (As illustrated).

AC voltage running to the bridge rectifier (approximate):

No-load off the generator 16.0 volts AC
Full-load off the generator 17.5 volts AC

Normal DC voltage running out of the rectifier (in volts DC) is measured across the two DC connections of the bridge rectifier; that is + and -.

DC voltage running from the bridge rectifier (approximate):

No-load off the generator 17.0 volts DC
Full-load off the generator 18.5 volts DC

2. AC winding: 0.14 ohm

Lift the two AC wire leads off the bridge rectifier and measure, the resistance between these two leads with an ohmmeter. It should measure 0.14 ohm. No continuity should exist between these two leads and the ground or the main AC stator windings.

3. Testing the Bridge Rectifier (meter used - Simpson 260)

- Set your ohmmeter's scale on RX1 (+ DC) and set the needle to zero.
- Connect the (+) positive lead from the ohmmeter to point #4. Taking the ohmmeter's negative (-) lead, momentarily touch points #1, #2, #3, and #5. The ohmmeter should register no deflection for any of the points touched.
- Remove the positive (+) lead from point #4 and connect the negative (-) lead; momentarily touch points #1, #2, and #3. The ohmmeter's needle should deflect when each point is touched.
- Leaving the negative ohmmeter (-) lead on point #4, touch point #5 with the positive lead. No deflection should take place.
- Place the positive (+) lead on point #1 and the negative (-) lead on point #3. The ohmmeter again should not register any deflection (no deflection indicated infinite resistance). Reverse these connections and the ohmmeter should again register no deflection. If the rectifier fails any of the previous tests (A-E), replace the rectifier because it is defective.

NOTE: Different types and/or brands of test meters may produce opposite test results.

BRIDGE RECTIFIER

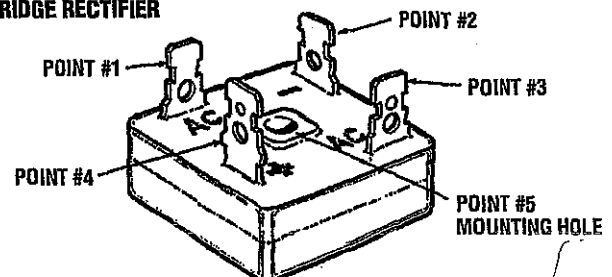

5.5/5.0KW EDC GENERATOR SINGLE PHASE

TESTING THE EXCITER WINDINGS

RESIDUAL VOLTAGE: Dual Exciter 7 - 9 Volts AC from each winding

An AC voltage is induced in these windings by the rotating field. Checking the residual voltage output from this winding can determine the condition of the winding when troubleshooting.

AC voltage can be measured across the capacitor(s) while the generator is operating. This voltage may be as high as 400 to 500 volts AC. This voltage buildup is accomplished as the exciter windings charge the capacitor(s) and the capacitor(s) discharge back into the exciter windings. This AC voltage reading is taken between the #60 Hertz connector and the # connection plugged into the capacitor(s) while the generator is operating at its rated Hertz (61.5 - 62.0). This flow of saturating AC in the exciter windings produces a phase-imbalance type of field that effects the auxiliary windings: a beneficial result that produces good motor starting characteristics for this type of generator.

To measure the resistance value of the exciter windings, locate the #9 and the #50 Hertz capacitor connections.

NOTE: Three numbered capacitor connections exist: #7, #8, and #9; and two Hertz connections, #50 and #60.

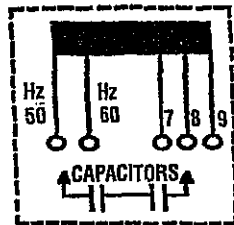
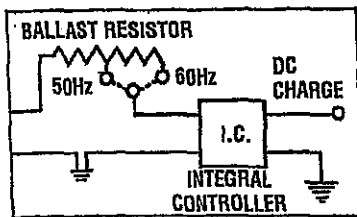

Unplug any other connections from the capacitor(s) noting their position on the capacitor. Place one lead of the ohmmeter on plug connection #9 and the other lead on plug connection #50 Hertz. Measure the resistance value of the exciter windings. Check to make sure there is no continuity to the ground/generator case from either of the two leads. Also check that no continuity exists between either the #50 Hertz plug or the #9 plug and any of the main stator windings leads on the AC terminal block. If continuity is found here, a fault exists between these two winding groups.
RESISTANCE: Dual Exciter 1.3 Ohms

FIELD TESTING CAPACITORS

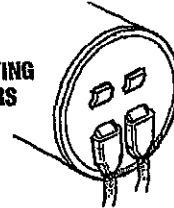

FIELD-TESTING THE CAPACITOR

With a capacitor meter, test the capacitor following the instructions included with the meter, and compare the results with the value shown on the capacitor. When a capacitor meter is not available, perform the following simple test:

1. Marking them so they may be reattached correctly, unplug the connections from the capacitor.
2. With a jumper, short across the two connections exposed in the previous step. This ensures the capacitor is discharged as it would be at shutdown.
3. With an ohmmeter set on the high R scale, place its plus (+) lead on one capacitor connection and the negative (-) lead on the other capacitor connection. A resistance should be read and should rise slowly as the meter attempts to charge the capacitor. This indicates a presumably good capacitor.
4. Indications of a defective capacitor:
 - a. Zero resistance or no rise in resistance value (shorted capacitor).
 - b. Infinite resistance (open capacitor).
 - c. No continuity should be found between the capacitor's connections and the capacitor's case or base.
5. Capacitor Ratings (Capacitor meter)
 - a. Dual Capacitor Units: 18.0 microfarads (uF) 5°

NOTE: Ratings are found on the capacitor case.
18.0- Microfarad capacitor PN 039556.

5.5/5.0KW EDC GENERATOR SINGLE PHASE

6. 12 volt DC excitation (low or no AC output voltage) the generator may be excited using 12 volts DC taken from the engine's starting battery. This voltage is applied across the #50 and #9 leads of the exciter circuit windings with any other numbered leads unplugged from the capacitors(s). The generator's reaction during flashing will help determine its fault.

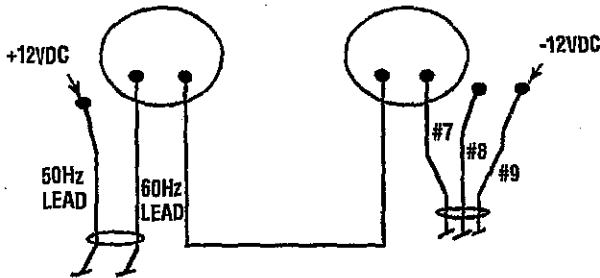

7. During 12 volt excitation, output voltage ranges are as follows:

Dual Exciter 12 - 14 VAC

- A slight rise in the output voltage with the loading of the engine and/or a growling noise from the generator end will indicate a fault in the main stator windings.
- No rise or very slight rise in the output voltage will indicate a fault in the exciter windings.
- Normal output voltage as specified above, check exciter circuit capacitor(s).

SHORE POWER TRANSFER SWITCH CONNECTIONS

Shore Power Connections

If the installer connects shore power to the vessel's AC circuit, this must be done by means of the Shore Power Transfer Switch. Set the transfer switch shown in the diagrams to the OFF position. This switch prevents simultaneous connection of shore power to generator output.

CAUTION: Damage to the generator can result if utility shore power and generator power are connected at the same time. This type of generator damage is not covered under the warranty; it is the installer's responsibility to make sure all AC connections are correct.

120 Volt/60 Hertz Three Wire Configuration

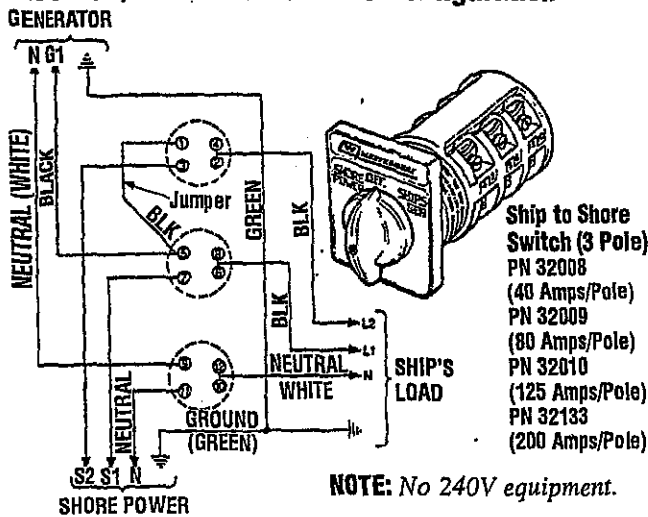

230 Volt/50 Hertz Two Wire Configuration

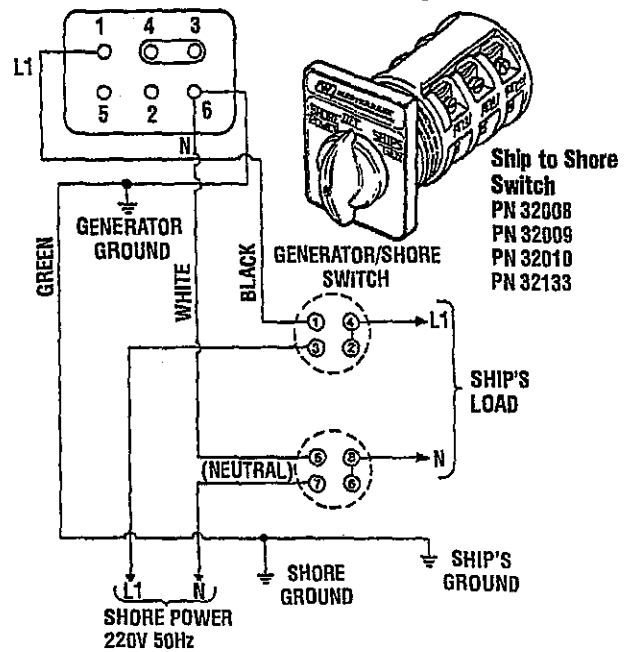

Switching Shore Power to Generator Power

CAUTION: Heavy motor leads should be shut off before switching shore power to generator power or vice-versa because voltage surges induced by switching with heavy AC loads on the vessel being operated may cause damage to the exciter circuit components in the generator.

5.5/5.0KW EDC GENERATOR SINGLE PHASE

Testing Component Resistance Values

Rotating Field/Auxiliary Windings and Diodes

Two sets of windings are found in the rotor assembly. An AC voltage is produced in two groups of windings as the rotor turns at rated rpm. The AC voltage passes through each of the two diodes mounted on the isolated fixture just before the rotor carrier bearing. The AC sine wave is changed to a DC and this DC voltage is passed through the two groups of rotating field windings producing a DC field around these windings. This field affects the AC winding of the two main stator groups inducing an AC voltage in these windings that is available at the AC terminal block connections.

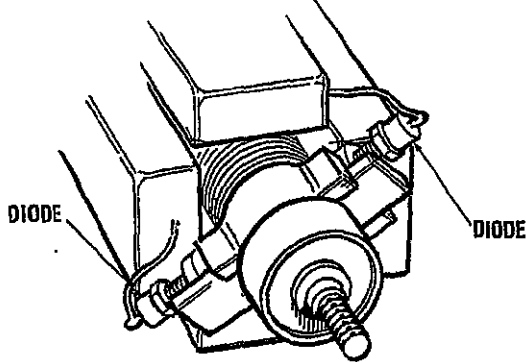

1. Rotating Field/Auxiliary Windings (3.8 Ohm)

To check the resistance values, rotate the engine's crankshaft to position the diode(s) on the generator's shaft at 12 o'clock. To make a quick check of these windings, presume the diode is OK and place one of the ohmmeter's leads on the connection at the top of the diode and the other lead at the connection at the base of the diode. Compare readings with the value above. If a distinct difference is noted in the ohm value, carefully unsolder the lead on the top of the diode and remove the diode from its isolated heat sink using a thin walled, deep well 7/16 in (11 mm) socket.

NOTE: The aluminum heat sink that the diode threads into can be bent carefully outboard to make easier access to the diode.

With the diode removed, both leads for the first group of rotating field/auxiliary windings will be isolated with no interference from a possibly faulty diode.

Check the resistance value of the rotating windings by placing the ohmmeter's leads across the two exposed leads.

Also, verify that no continuity exists between these windings and the rotor shaft by leaving one ohmmeter lead attached to the winding lead and the other ohmmeter lead touching the shaft: no continuity should exist. If continuity is found, a short exists.

Repeat this same check on the second group of windings. Rotate the engine's crankshaft 180° to position the second diode and connections at 12 o'clock.

No continuity should be found between these two groups of windings.

2. Diodes 8 - 9.5 ohms (approximate) using a 260 Simpson Analog Meter

To check the diode, unsolder the connection from the top of the diode. Place one ohmmeter lead on the connection at the top of the diode and the other ohmmeter lead to the diode's base. Then reverse the position of the ohmmeter leads.

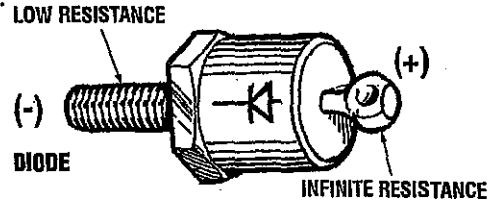

A low resistance should be found with the leads in one direction, and infinite resistance (blocking) in the other direction. Different meters will read different resistance values through the diode.

NOTE: Different meter models may show different ohm values, but should read the same for both diodes.

Diode Rating: 1600 amps 26 Amps

The diode's rating is far in excess of the circuit's requirements. Most likely a diode failure will result from an overspeed or load surge.

Main Stator Windings (BC Model 0.3 Ohms)

Residual voltage measured between #1-#3 and #4-#6 will be 2-3 volts AC between each pair of leads at the terminal block. This would be an indication that the stator windings are okay. Check exciter windings and artificially excite the generator.

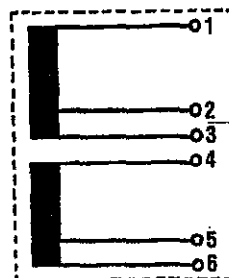

NOTE: The numbered leads on the terminal block are not in any numerical order. They are shown below.

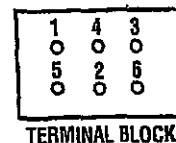

Group #1 - Measure resistance value between terminal with lead #1 and terminal with lead #3. (Check that there is no continuity of Group #1 windings to the case ground.)

Group #2 - Measure resistance value between terminal with lead #4 and terminal with lead #6. (Check that there is no continuity of Group #2 windings to the case ground.)

Check for a possible short between the two groups of stator windings by placing one lead of the ohmmeter on the terminal with the stator lead #3 and the other ohmmeter lead on the terminal with stator lead #6. There should be no continuity between the two groups of stator windings.

SPECIAL TOOLS - GENERATOR

FIELD FABRICATED TOOLS

These drawings provide a means by which simple tools can be made to assist in the removal of the generator end from the engine and in the replacement of the generator end on the engine. A local machine shop should be able to fabricate these tools at a modest price, but first check with your local WESTERBEKE dealer to see if these tools are on hand for loan.

Housing Puller Tool

This tool allows the bearing in the generator housing to be gently pushed straight off the housing without any twisting. If a nut of the same specifications as that of the tapped hole in the pilot tool were to be welded on the end of the eye bolt, this tool would be able to pull the bearing back into place without any twisting. Please refer to these drawings before the generator end is removed.

HOUSING PULLER TOOL (FIELD FABRICATED)

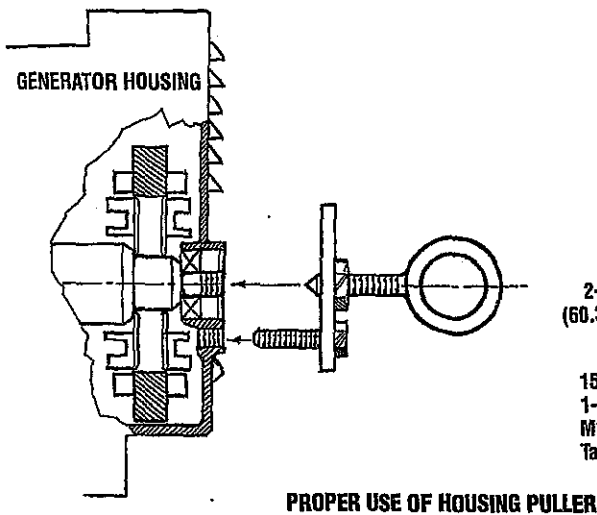
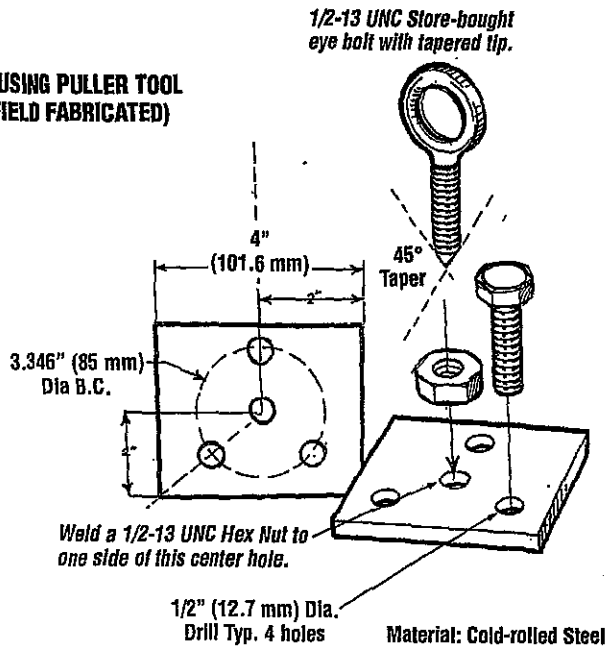

Lifting Eye Tool

This tool allows a mechanic to safely remove the generator end from the engine by attaching this Generator End Lifting Eye to the four screw holes located under the control panel. To use this Lifting Eye, remove the generator's control panel and screw the Lifting Eye to the generator end.

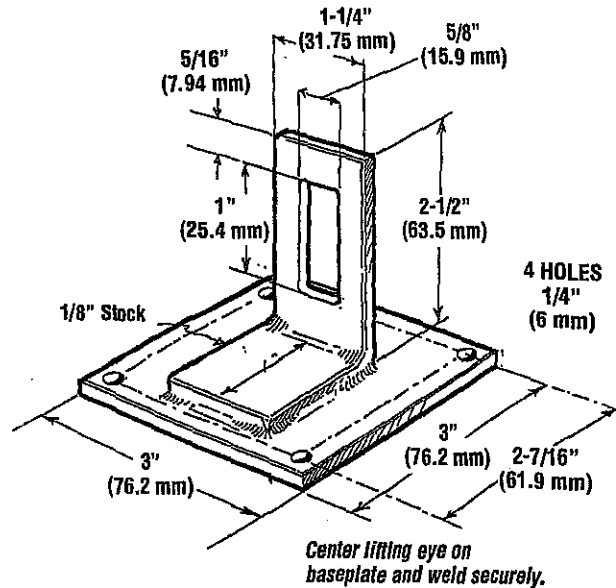

Disk Alignment Tool

This tool allows a mechanic to safely remove and install the generator drive disks by aligning the disks with the Drive Plate Guide Pin. The Pin screws into the flywheel and acts as a guide. Also the pin helps to support some of the rotor and the drive plate's weight while removing or replacing these parts.



Material: One M8 bolt with the hex head machined off and a screwdriver slot cut in the machined end.

Pilot Tool

The tool below helps keep the rotor from damaging the windings in the generator housing to be removed straight off the engine or to be placed straight on the engine. Refer to the removal and replacement diagram at the bottom of the page.

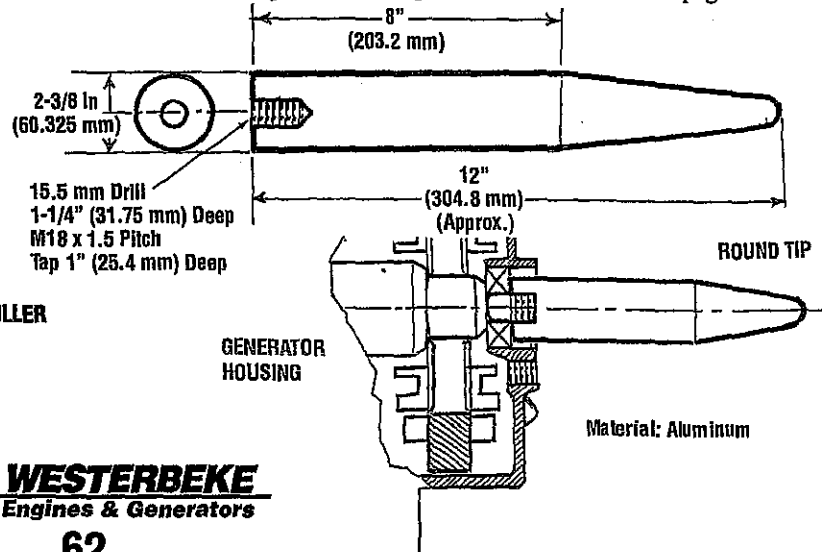

SERVICE DATA / STANDARDS AND LIMITS

7.6/5.7 EDT AND 5.5/5.0 EDC GENERATORS

Component	Specified Value / Standard Inches(mm)	Repair Limit Inches(mm)
-----------	--	----------------------------

COMPRESSION / TIMING

Cylinder Compression398.16 psi at 280 rpm355.5 psi
Pressure (28 kg/cm²) (25 kg/cm²)

Difference between35.55 psi
Cylinders (max) (2.5 kg/cm²)

Fuel Injection Order1 - 3 - 2

Injection Timing at BTDC
on compression stroke19° ± 1.519° ± 2
Spill Timing (static)

Injector Spray Pressure1990 psi ± 140.0
(140 ± 10.0 Kg/cm²)

CYLINDER HEAD

Bottom Surface Distortionwithin 0.002 (0.05)0.004 (0.1)

Valve Guide I.D.0.260 (6.6)
(Intake & Exhaust)

Valve Guide Angle45°
(Intake & Exhaust)

Valve Guide Width0.051 - 0.071 (1.3 - 1.8)0.004 (0.1)
(Intake & Exhaust)

Valve Clearance0.010 (0.25) Gold
(Intake & Exhaust)

VALVES

Valve Head Diameter (Intake)1.051 (26.7)

Valve Head Diameter (Exhaust)0.972 (24.7)

Overall Length3.701 (94)

Stem O.D.0.260 (6.6)

Stem to Guide Clearance (Intake)1.051 (26.7)

Stem to Guide Clearance (Exhaust)0.972 (24.7)

Valve Contact Width31.3 - 1.8

Valve Face Angle45°

Valve Head Thickness0.039 (1.0)0.019 (0.5)
Margin Width)

Valve Head Sinkage (from0.019 (0.5)0.591 (1.5)
cylinder head to bottom face)

Valve Spring
Free Length1.595 (40.5)1.547 (39.3)
Preload/Installed Length13.095 lbs/1.398 in-15%
(5.94 kg/35.5mm)

Squareness2°3°

TIMING GEARS

Backlash between gears in Mesh
0.0003 - 0.0005(0.01 - 0.14)0.012(0.3)

Idle Gear Bushing - Clearance
between Bushing and Shaft
0.001 - 0.010(0.03 - 0.07)0.0078(0.2)

ROCKER ARM

Interior Diameter0.047 (12)

Rocker Arm to Shaft Clearance-0.008 (-0.2)

Component	Specified Value / Standard Inches(mm)	Repair Limit Inches(mm)
-----------	--	----------------------------

CYLINDER BLOCK

Camshaft Hole Diameter
Front1.654 (42)Ball Bearing Hole
No. 21.339 (34)
No. 31.299 (33)
Rear1.299 (33)

CYLINDER BORE

Bore Size
5.0KW2.559 (65)+0.008(+0.2)
7.6KW2.992 (76)+0.008(+0.2)

Oversize Finish Tolerance0 - 0.001 (0-0.03)
.....for each oversize

Cylindricity
5.0KWwithin 0.0004 (0.01)
7.6KWwithin 0.0020 (0.05)

Gasket Fitting/within 0.0020 (0.05)0.004 (0.1)
Surface Distortion

PISTON

TypeSolid Type

MaterialAluminum Alloy

Outside Diameter -
Skirt End 55 mm from top
5.0KW2.559 (65)
7.6KW2.992 (76)

Clearance to Cylinder0.0028 - 0.0079(0.071 - 0.084)0.001 (0.3)

Oversize0.01, 0.02, 0.03
(0.25, 0.50, 0.75)

Protrusion From Cylinder0.035 (0.9)
Block Top Surface

PISTON PIN

TypeSemi-floating Type

Outside Diameter0.709 (18)

Piston Pin to Piston Clearance0.003 (0.08)

Piston Pin to Connecting
Rod Clearance
Press-fit Load2204.6 ± 1102.3 lbs (1000 ± 500 kg)

PISTON RINGS

Number of Rings
Compression (2)
No. 1Chrome plated, semi-keystone type
No. 2Tapered

Oil (1)Chrome plated with Coil expander

Ring Side Clearance
Compression No. 10.3
Compression No. 20.002 - 0.004 (0.05 - 0.09)0.008 (0.2)
Oil0.001 - 0.002 (0.03 - 0.07)0.008 (0.2)

Ring Gap (All Rings)0.006 - 0.016 (0.15 - 0.40)(1.5)



SERVICE DATA / STANDARDS AND LIMITS

7.6/5.7 EDT AND 5.5/5.0 EDC GENERATORS

Component	Specified Value / Standard Inches(mm)	Repair Limit Inches(mm)	Component	Specified Value / Standard Inches(mm)	Repair Limit Inches(mm)
CONNECTING ROD BEARING			INJECTION PUMP CAMSHAFT		
Type	Aluminum with Black Metal		Driving Method	Gear Drive	
Oil Clearance	0.0009 - 0.0020 (0.022 - 0.052)	0.006 (0.15)	Front Journal	Ball Bearing (Front & Rear)	
Under Size	0.01, 0.02 (0.25, 0.50)		Lobe Height	1.18 (30.0)	0.027 (0.7)
CONNECTING ROD			TAPPET		
Type	Forged I-Beam		Outside Diameter	0.75 (19)	
Bend and Twist	Within 0.002 (0.05)		Tappet to Cylinder Block Clearance		0.006 (0.15)
Big End Thrust Clearance	0.004 - 0.014 (0.1 - 0.35)		PUSH ROD		
CRANKSHAFT			Bend	Within 0.0118 (0.3)	
Type	Fully Counterbalanced		Fuel Solenoid Cut-Off Stroke	(10 ± 0.5)	
Bend	Within 0.001 (0.03)		STARTER MOTOR		
End Play	0.002 - 0.007 (0.05 - 0.175)		Depth of Brush Undercut	0.019 (0.5)	0.008 (0.2)
Journal O.D.	1.693 (43)	-0.006 (-0.15)	Height of Brush	0.689 (17)	0.236 (6)
Pin O.D.	1.575 (40)	-0.006 (-0.15)	Spring Pressure	43 Lb/in ² (3 Kg/cm ²)	
Bearing Oil Clearance	(0.022 - 0.052)		Commutator O.D.	1.523 (38.7)	-0.039 (-1.0)
Under Size Finishing			Pinion Shaft End Play	0.014 (0.5)	
Journal Under Size					
0.25	1.6817 - 1.6823 (42.715 - 42.730)				
0.50	1.6719 - 1.6724 (42.465 - 42.480)				
Pin Under Size					
0.25	1.5636 - 1.5642 (39.715 - 39.730)				
0.50	1.5537 - 1.5543 (39.465 - 39.480)				
MAIN BEARING					
Type	Aluminum with Black Metal				
Oil Clearance	No. 2: Flanged Metal				
Under Size	0.01, 0.02 (0.25, 0.50)				
VALVE CAMSHAFT					
Driving Method	Gear Drive				
Front Journal	Ball Bearing				
Journal to Cylinder Block Hole Clearance		0.006 (0.15)			
Lobe Height	1.078 (27.37)	0.039 (1.0)			
Major Diameter of Cam (Intake and Exhaust)	1.078 (27.37)	0.039 (-1.0)			
Oil Clearance		0.006 (0.15)			

TORQUE SPECIFICATIONS - 7.6/5.7KW AND 5.5/5.0KW GENERATORS

COMPONENT	FT-LB (M-KG)
Alternator Bracket	27 - 38 (3.8 - 5.3)
Back Plate	24 - 35 (3.3 - 4.8)
Connecting Rod Cap M8 (14)	23 - 28.2 (3.2 - 3.5)
Coolant Pump	12 - 17 (1.6 - 2.4)
Coolant Pump Pulley.....	12 - 17 (1.6 - 2.4)
Coolant Temperature Sender	9 - 13 (1.2 - 1.8)
Coolant Temperature Sensor	9 - 13 (1.2 - 1.8)
*Cylinder Head Bolts (wet)	
M8 (12) Bolts 1, 2, 3	14 - 21 (2.0 - 3.0)
M10 (14) Bolts 4 - 11	54 - 61 (7.8 - 8.5)
Cylinder Head Cover	2 - 3 (0.3 - 0.45)
Engine Mounts	23 - 34 (3.2 - 4.7)
Exhaust Manifold.....	20 - 24 (2.7 - 3.3)
Actuator Locknut	
M30 (36).....	28.9 - 36.2 (4.0 - 5.0)
Flywheel bolt M10 (17)	61 - 68 (8.5 - 9.5)
Glow Plug, M10 (12).....	11 - 14.5 (1.5 - 2.0)
Glow Plug Lead Wire Fitting Nut,	
M4 (7).....	0.7 - 1.0 (0.1 - 0.15)
Governor Assembly	
Relief Plunger Assembly	28.9 - 36.2 (4.0 - 5.0)
Taper Plug	11 - 23 (1.5 - 2.2)
Idler Gear Thrust Plate	15 - 23 (2.2 - 3.2)
Injection Nozzle to Body	25.3 - 36.2 (3.5 - 4.0)
Injection Pipe Flare Nut.....	18 - 22 (2.5 - 3.0)
Injection Pipe Nut, M12 (17)	18 - 25 (2.5 - 3.5)
Injection Pump Delivery Valve Holder	
M16 (17).....	25.3 - 28.2 (3.5 - 3.9)
Injection Pump Drive Gear	
Lock Nut	29 - 51 (4.0 - 7.0)

COMPONENT	FT-LB (M-KG)
Injection Pump Hollow Screw	
M10 (14).....	7.2 - 10.8 (1.0 - 1.5)
Injectors.....	36 - 38 (5.0 - 6.0)
Intake Manifold	12 - 17 (1.6 - 2.4)
Main Bearing Cap	36 - 38 (5.0 - 5.5)
Nozzle Holder (fitting to engine),	
M20 (21).....	36.1 - 43.3 (5.0 - 6.0)
Nozzle Retaining Nut,	
M16 (21).....	25.3 - 28.9 (3.5 - 4.0)
Nozzle Union Color Fixing Nut,	
M12 (17).....	18.0 - 21.6 (2.5 - 3.0)
Oil Drain Hose Plug M18 (19)	36.1 - 43.3 (5.0 - 6.0)
Oil Filter	
M20 (17).....	7.9 - 9.4 (1.1 - 1.3)
Oil Pan Bolts	12 - 17 (1.6 - 2.3)
Oil Pressure Sensor	9 - 13 (1.2 - 1.8)
Oil Relief Plug	28.9 - 36.1 (4.0 - 5.0)
Rear Oil Seal Cap.....	11 - 14 (1.5 - 2.0)
Rocker Arm Assembly	11 - 15 (1.5 - 2.2)
Rocker Arm Cover.....	1.8 - 2.9 (0.25 - 0.40)
Rocker Cover Nut, M6 (10)	3.6 - 5.0 (0.5 - 0.7)
Rocker Shaft Hold-down Bolt,	
M8 (12).....	10.8 - 15.9 (1.5 - 2.2)
Thermostat Housing	6 - 8 (0.8 - 1.1)
Timing Gear Case	12 - 17 (1.6 - 2.4)
Torque Spring Set Locknut	6 - 9 (0.8 - 1.2)

NOTE: Hardware listed is metric, with values given as follows:

Flywheel Bolt, M10 (17)

M10 indicates Metric, 10mm thread diameter;

(17) indicates 17mm across the flats of the bolt head.

**(wet) indicates that the bolts (if removed) are to have a thin oil film wiped on them before they are retorqued. If the bolts have not been removed and need only to be retorqued, then no oil is needed.*

STANDARD HARDWARE TORQUES

NOTE: Unless stated otherwise for a specific assembly, use the following torque values when tightening standard hardware.

Grade 4	Pitch	lb-ft	kg-m
6mm bolt head/nut	1	2.9-5.1	0.4-0.7
8mm bolt head/nut	1.25	7.2-11.6	1.0-1.6
10mm bolt head/nut	1.25	13.7-22.4	1.9-3.1
10mm bolt head/nut	1.5	13.0-21.7	1.8-3.0
12mm bolt head/nut	1.25 (ISO)	25.3-39.8	3.5-5.5
12mm bolt head/nut	1.5	25.3-39.8	3.5-5.5
12mm bolt head/nut	1.75	21.7-36.2	3.0-5.0
13mm bolt head/nut	1.5	32.5-50.6	4.5-7.0
14mm bolt head/nut	1.5	36.2-57.9	5.0-8.0
14mm bolt head/nut	2	34.0-55.7	4.7-7.7
16mm bolt head/nut	1.5	54.2-79.6	7.5-11.0
16mm bolt head/nut	2	51.4-76.7	7.1-10.6
Grade 6T			
6mm bolt head/nut	1	4.3-6.5	0.6-0.9
8mm bolt head/nut	1.25	10.8-15.9	1.5-2.2
10mm bolt head/nut	1.25	21.7-32.5	3.0-4.5
10mm bolt head/nut	1.5	19.5-30.4	2.7-4.2
12mm bolt head/nut	1.25 (ISO)	36.2-57.9	5.0-8.0
12mm bolt head/nut	1.5	36.2-50.6	5.0-7.0
12mm bolt head/nut	1.75	34.7-49.2	4.8-6.8

Grade 7T, 8T and 8.8	Pitch	lb-ft	kg-m
6mm bolt head/nut	1	5.8-8.7	0.8-1.2
8mm bolt head/nut	1.25	14.5-21.7	2.0-3.0
10mm bolt head/nut	1.25	28.9-39.8	4.0-5.5
10mm bolt head/nut	1.5	26.8-37.6	3.7-5.2
12mm bolt head/nut	1.25 (ISO)	54.2-75.9	7.5-10.5
12mm bolt head/nut	1.5	50.6-65.1	7.0-9.0
12mm bolt head/nut	1.75	43.4-61.5	6.0-8.5
13mm bolt head/nut	1.5	57.9-86.8	8.0-12.0
14mm bolt head/nut	1.5	72.3-108.5	10.0-15.0
14mm bolt head/nut	2	68.7-101.3	9.5-14.0
16mm bolt head/nut	1.5	108.5-166.4	15.0-23.0
16mm bolt head/nut	2	101.3-159.1	14.0-22.0
Grade 5 Cap Screw			
1/4 UNC		9-11	1.2-1.5
1/4 UNF		11-13	1.5-1.8
5/16 UNC		18-20	2.5-2.8
5/16 UNF		21-23	2.9-3.2
3/8 UNC		28-33	3.7-4.6
3/8 UNF		30-35	4.1-4.8
7/16 UNC		44-49	6.1-6.8
7/16 UNF		50-55	6.9-7.6
1/2 UNC		68-73	9.4-10.1
1/2 UNF		73-80	10.1-11.1

BOLT DIAMETER	BOLT HEAD MARK		
	4	7	10
M6	0.3 - 0.5	0.8 - 1.0	1.0 - 1.3
M8	1.0 - 1.3	1.5 - 2.2	2.5 - 3.5
M10	1.8 - 2.5	3.0 - 4.2	5.0 - 7.0
M12	3.0 - 4.2	5.5 - 7.5	9.5 - 12.0
M14	5.0 - 7.0	8.0 - 11.0	16.0 - 19.0

PARTS REQUIRING SEALANT	SURFACES REQUIRING SEALANT (where to mount sealant coated parts)	SEALANT
Taper Screw 1/2"	Thread portion (Gear Case)	Liquid Teflon
Taper Screw 1/4"	Thread portion (Cylinder Block right side, pump cover)	Liquid Teflon
Taper Screw 1/8"	Thread portion (Cylinder Head rear surface)	Liquid Teflon
Water Drain Plug	Thread portion (Cylinder Block right side, rear middle portion)	Liquid Teflon
Oil Pressure Switch	Thread portion (Cylinder Block right side surface)	Liquid Teflon
Slide Seal	Periphery (Main Bearing Caps No. 1 and No. 5)	Permatex #6B
Bearing Cap No. 1	Contact surface with Cylinder Block	Permatex #6B

METRIC CONVERSIONS

INCHES TO MILLIMETERS				MILLIMETERS TO INCHES			
Inches	mm	Inches	mm	mm	Inches	mm	Inches
1	25.40	15	381.00	1	0.0394	15	0.5906
2	50.80	20	508.00	2	0.0787	20	0.7874
3	76.20	25	635.00	3	0.1181	25	0.9843
4	101.60	30	762.00	4	0.1575	30	1.1811
5	127.00	35	889.00	5	0.1969	35	1.3780
10	254.00	40	1016.00	10	0.3937	40	1.5748

10 MILLIMETERS = 1 CENTIMETER, 100 CENTIMETERS = 1 METER = 39.37 INCHES (3.3 FEET)

INCHES TO METERS				METERS TO INCHES			
Inches	Meters	Inches	Meters	Meters	Inches	Meters	Inches
1	0.0254	7	0.1778	0.1	3.937	0.7	27.559
2	0.0508	8	0.2032	0.2	7.874	0.8	31.496
3	0.0762	9	0.2286	0.3	11.811	0.9	35.433
4	0.1016	10	0.2540	0.4	15.748	1.0	39.370
5	0.1270	11	0.2794	0.5	19.685	1.1	43.307
6	0.1524	12	0.3048	0.6	23.622	1.2	47.244

TO CONVERT METERS TO CENTIMETERS, MOVE DECIMAL POINT TWO PLACES TO THE RIGHT

YARDS TO METERS				METERS TO YARDS			
Yards	Meters	Yards	Meters	Meters	Yards	Meters	Yards
1	0.91440	6	5.48640	1	1.09361	6	6.56168
2	1.82880	7	6.40080	2	2.18723	7	7.65529
3	2.74320	8	7.31520	3	3.28084	8	8.74891
4	3.65760	9	8.22960	4	4.37445	9	9.84252
5	4.57200	10	9.14400	5	5.46807	10	10.93614

MOVE DECIMAL POINT FOR HIGHER VALUES — e.g. 6,000 METERS = 6,561.68 YARDS

POUNDS TO KILOGRAMS				KILOGRAMS TO POUNDS			
lb	kg	lb	kg	kg	lb	kg	lb
1	0.454	6	2.722	1	2.205	6	13.228
2	0.907	7	3.175	2	4.409	7	15.432
3	1.361	8	3.629	3	6.614	8	17.637
4	1.814	9	4.082	4	8.818	9	19.842
5	2.268	10	4.536	5	11.023	10	22.046

GALLONS TO LITERS				LITERS TO GALLONS			
Gallons	Liters	Gallons	Liters	Liters	Gallons	Liters	Gallons
1	3.79	10	37.86	1	0.26	60	15.66
2	7.57	20	75.71	2	0.53	90	23.77
3	11.36	30	113.57	5	1.32	120	31.32
4	15.14	40	151.42	10	2.64	150	39.62
5	18.93	50	189.28	20	5.28	180	47.54

PINTS TO LITERS				LITERS TO PINTS			
Pints	Liters	Pints	Liters	Liters	Pints	Liters	Pints
1	0.47	6	2.84	1	2.11	6	12.68
2	0.95	7	3.31	2	4.23	7	14.79
3	1.42	8	3.79	3	6.34	8	16.91
4	1.89	9	4.26	4	8.45	9	19.02
5	2.37	10	4.73	5	10.57	10	21.13

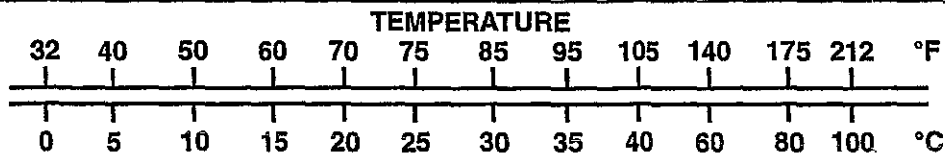

INDEX

AC Voltage Connections	57, 58	Injection Pump.....	25
Alternator Testing	38	Injection Pump Camshaft Removal.....	14
Block - Cylinder	19	Injection Timing	26
Bridge Rectifier.....	50	Injectors - Fuel	27
Camshaft	14	Maintenance - Generator	45
Circuit Breaker - Generator	46, 54	Manifold - Exhaust	24
Connecting Rod	15	Metric Conversion Chart	67
Compression-Engine.....	37	Oil Pressure	36
Coolant Circulating pump	30	Oil Pressure Sender	36
Crankshaft	17	Oil Pressure Switch	36
Cylinder Block.....	19	Oil Seal - Front	13
Cylinder Head, Inspection	10	Oil Seal - Rear	17
Cylinder Head, Install	10	Parts Ordering	2
Cylinder Head, Remove	9	Piston and Piston Ring	15, 16, 17
Cylinder Block Inspection.....	19	Piston Assembly	16
Cylinder Head Bolt Pattern	9, 12	Pumps:	
Digital Control Box	41	Coolant Circulating	30
Electric Motors - Chart	45	Fuel Lift.....	28
Engine Adjustments	37	Injection.....	26
Engine Assembly	22	Raw Water (Overhaul)	31
Engine Compression	37	Push Rod	15
Engine Disassembly	8	Raw Water Pump Overhaul	31
Engine Specifications	54, 63	Rear Oil Seal	17
Exhaust Manifold	24	Screws - Standards	68
Frequency - Adjustment	37, 48	Sealants	68
Front Oil Seal	13	Sender - Oil Pressure	36
Fuel Injection Pump	25	Serial Number Location	2
Fuel Injectors	27	Shore Power Transfer Switch	53, 60
Fuel Lift Pump.....	28	Specifications - Engine	54, 63
Fuel Run Solenoid.....	21, 27	Specifications - Generators	43, 44
Gears	14, 15	Speed Adjustment	21
Generator Disassembly	8	Spill Timing.....	26
Generator Tech Data - 5.5/5.0 EDC	54	Standards and Limits	63
Generator Tech Data - 7.6/5.7 EDT	46	Starter Motor	32
Generator Wiring Diagram	46, 49	Switch - Oil Pressure.....	36
Generator Maintenance	45	Tappet - Inspection	15
Generator Specifications	43, 44	Testing for Overhaul	7
Generator Information	45	Thermostat Assembly	22
Generator Wiring Schematic	42, 44	Timing Gear Case	13
Glow Plugs	29	Timing Cover.....	13
Governor	20	Timing Gear Inspection	14
Governor Shaft	13	Timing Gear Installation	14
Heat Exchanger	24	Timing Gear Removal	14
Idler Gear.....	14, 15		

INDEX

Tolerances and Limits:	63	Troubleshooting:	
Camshaft	64	Alternator	37
Connecting Rod/Connecting Rod Bearing	64	EDC Generator	55
Crankshaft and Main Bearing	64	EDT Generator	47
Cylinder Block, Piston and Piston Pin	64	Engine	3
Cylinder Head and Valve Spring.....	63	Valve Camshaft Removal	14
Rocker Arm and Rocker Shaft	63	Valve Clearance	12, 37
Starter Motor	64	Valve Guide Replacement	10
Tappet	64	Valve Inspection.....	11
Timing Gear	63	Valve Installation	11
Valve Guide, Valve and Valve Spring	63	Valve Removal.....	11
Valve Timing	63	Valve Seat Repair	10
Torque Spring Set.....	20	Valve Spring.....	11
Tools-Generator Disassembly.....	62	Wiring Diagrams:	
Torques:		7.6/5.7 and 5.5/5.0 Wiring Diagram	42
Standard Hardware	66		
Westerbeke Components	65		

